

**RECORD POWER**  
ESTABLISHED 1909®

## Original Instruction Manual

# TS2 315 mm Heavy Duty Table Saw with Extendable Mitre Fence

Version 3.1  
April 2020



To register this product please visit  
**[www.recordpower.info](http://www.recordpower.info)**

It is important to register your product as soon as possible in order to receive efficient after sales support and be entitled to the full **5 year guarantee**. Your statutory rights are not affected. Please see back cover for contact details.



Always wear safety glasses when using woodworking equipment.



Always read the instructions provided before using woodworking equipment.

### Important

For your safety read instructions carefully before assembling or using this product.

Save this manual for future reference.

# Contents

- 1** Explanation of Symbols
  - 2** General Health and Safety Guidance
  - 3** Additional Health and Safety Guidance for Table Saws
  - 4** Record Power Guarantee
  - 5** Specifications
  - 6** Getting to Know the TS2
  - 7** Contents of the Package
  - 8** Assembly
  - 9** Operation
  - 10** Dust Extraction
  - 11** Maintenance
  - 12** Troubleshooting
  - 13** Electrical Connection and Wiring Diagram
  - 14** Parts Lists and Diagrams
- EU Certificate of Conformity

# 1. Explanation of Symbols

**THE SYMBOLS AND THEIR MEANINGS SHOWN BELOW MAY BE USED THROUGHOUT THIS MANUAL. PLEASE ENSURE THAT YOU TAKE THE APPROPRIATE ACTION WHEREVER THE WARNINGS ARE USED.**

## **Mandatory Instructions**



Read and fully understand the instruction manual before attempting to use the machine.



Indicates an instruction that requires particular attention



Wear protective eyewear



Use respiratory protective equipment



Use hearing protection



Use suitable protective footwear



Use protective work gloves

## **Warning**



Indicates a risk of severe personal injury or damage to the machine



Indicates a risk of severe personal injury from electrical shock



Risk of personal injury from lifting of heavy items



Indicates a risk of severe personal injury from airborne objects



Risk of fire

# 2. General Health and Safety Guidance

**Ensure that you carefully read and fully understand the instructions in this manual before assembly, installation and use of this product. Keep these instructions in a safe place for future reference.**

**WARNING:** for your own safety, do not attempt to operate this machine until it is completely assembled and installed according to these instructions.

**WARNING:** When using any machine, basic safety precautions should always be followed to reduce the risk of fire, electric shock and personal injury.

## Safe Operation

### 1. Use Personal Protective Equipment (PPE)

- The operation of any machine can result in foreign objects being thrown into your eyes, which can result in severe eye damage. Protective eyewear or other suitable eye protection or face shield should be used at all times. Everyday spectacles only have impact resistant lenses. They are not protective eyewear and do not give additional lateral protection.
- Use respiratory protective equipment (dust mask etc.) if the machining operation creates dust. Exposure to high levels of dust created by machining hardwoods, softwoods and man made composite boards can result in serious health problems. Some imported hardwoods give off highly irritating dust, which can cause a burning sensation. The use of respiratory protective equipment should not be seen as an alternative to controlling the risk of exposure at source by using adequate dust extraction equipment.
- The use of ear plugs or ear defenders is recommended when the machine is in use, particularly if the noise level exceeds 85 dB.
- Wear suitable protective gloves when handling cutting tools or blades. Gloves should NOT be worn when using the machine as they can be caught in moving parts of the machine.
- Non-slip safety footwear is recommended when using the machine and handling large work pieces.

### 2. Dress appropriately

- Do not wear loose clothing, neckties or jewellery; they can be caught in moving parts of the machine.
- Roll up long sleeves above the elbow.
- Wear protective hair covering to contain long hair.

### 3. Safety warnings

- Find and read any warning labels on the machine
- It is important that any labels bearing health and safety warnings are not removed, defaced or covered. Replacement labels can be obtained by contacting our Customer Service Department.

### 4. Familiarise yourself with the machine

- If you are not thoroughly familiar with the operation of this machine, obtain advice from your supervisor, instructor, or other qualified person or contact your retailer for information on training courses. Do not use this machine until adequate training has been undertaken.

### 5. Take care when moving or positioning the machine

- Some machines can be very heavy. Ensure the floor of the area in which the machine is to be used is capable of supporting the machine.
- The machine and its various components can be heavy. Always adopt a safe lifting technique and seek assistance when lifting heavy components. In some cases it may be necessary to use mechanical handling equipment to position the machine within the work area.
- Some machines have optional wheel kits available to allow them to be manoeuvred around the workshop as required. Care should be taken to install these according to the instructions provided.
- Due to the nature of the design of some machines the centre of gravity will be high making them unstable when moved. Extreme care should be taken when moving any machine.
- If transportation of the machine is required then all precautions relating to the installation and handling of the machine apply. In addition, ensure that any vehicles or manual handling equipment used for transportation

are of adequate specification.

### 6. The machine should be level and stable at all times

- When using a leg stand or cabinet base that is designed to be fitted to the machine, always ensure that it is securely fastened to the machine using the fixings provided.
- If the machine is suitable to be used on a workbench, ensure that the workbench is well constructed and capable of withstanding the weight of the machine. The machine should always be securely fastened to the workbench with appropriate fixings.
- Where possible, floor standing machines should always be secured to the floor with fixings appropriate to the structure of the floor.
- The floor surface should be sound and level. All of the feet of the machine should make contact with the floor surface. If they do not, either re-locate the machine to a more suitable position or use packing shims between the feet and the floor surface to ensure the machine is stable.

### 7. Remove adjusting keys and wrenches

- Ensure that all adjusting wrenches and keys are removed before switching the machine 'ON'. There is a risk of severe personal injury or damage to the machine from airborne objects.

### 8. Before switching the machine 'ON'

- Clear the machine table of all objects (tools, scrap pieces etc.)
- Make sure there is no debris between the work piece and the table / work support.
- Ensure that the work piece is not pressed against, or touching the saw blade or cutting tool.
- Check all clamps, work holding devices and fences to ensure that they are secure and cannot move during machining operations.
- Plan the way that you will hold and feed the work piece for the entire machining operation.

### 9. Whilst machining

- Before starting work, watch the machine while it runs. If it makes an unfamiliar noise or vibrates excessively, switch the machine 'OFF' immediately and disconnect it from the power supply. Do not restart until finding and correcting the source of the problem.

### 10. Keep the work area clear

- Working clearances can be thought of as the distances between machines and obstacles that allow safe operation of every machine without limitation. Consider existing and anticipated machine needs, size of material to be processed through each machine and space for auxiliary stands and/or work tables. Also consider the relative position of each machine to one another for efficient material handling. Be sure to allow yourself sufficient room to safely operate your machines in any foreseeable operation.
- Cluttered work areas and benches create the risk of accidents. Keep benches clear and tidy away tools that are not in use.
- Ensure that the floor area is kept clean and clear of any dust and debris that may create trip or slip hazards.

### 11. Consider the work area environment

- Do not expose the machine to rain or damp conditions.
- Keep the work area well lit and ensure that there is artificial lighting available when there is insufficient natural light to effectively light the work area. Lighting should be bright enough to eliminate shadow and prevent eye strain.
- Do not use the machine in explosive environments eg. in the presence of flammable liquids, gases or dust.
- The presence of high levels of dust created by machining wood can present a risk of fire or explosion. Always use dust extraction equipment to minimise the risk.

### 12. Keep other persons away (and pets)

- The machine is designed to be used by one person only.
- Do not let persons, especially children, touch the machine or extension cable (if used) and keep visitors away from the work area.
- Never leave the machine running unattended. Turn the power supply off and do not leave the machine unattended until it comes to a

## 2. General Health and Safety Guidance

complete stop.

- If the work area is to be left unattended, all machinery should be switched 'OFF' and isolated from the mains power supply.

### 13. Store machines safely when not in use

- When not in use, machines should be stored in a dry place, out of reach of children. Do not allow persons unfamiliar with these instructions or with the machine to operate it.

### 14. Do not overreach

- Choose a working position that allows your body to remain balanced and feed the work piece in to the machine without overreaching.
- Keep proper footing and balance at all times.

### 15. Electrical supply

- Electrical circuits should be dedicated to each machine or large enough to handle combined motor amp loads. Power outlets should be located near each machine so that power or extension cables are not obstructing high-traffic areas. Observe local electrical guidelines for proper installation of new lighting, power outlets, or circuits.
- The machine must be connected to an earthed power supply.
- The power supply must be equipped with a circuit breaker that provides short circuit, overload and earth leakage protection.
- The voltage of the machine must correspond to the voltage of the mains power supply.
- The mains plug fitted to the machine should always match the power outlet. Do not modify the plug in any way. If a replacement plug is required it should be fitted by a competent person and of the correct type and rating for the machine.
- If you are unsure about any electrical connections always consult a qualified electrician.

### 16. Avoid unintentional starting of the machine

- Most machines are fitted with a no-volt release (NVR) switch to prevent unintentional starting. If in doubt always ensure the machine switch is in the 'OFF' position before connecting it to the power supply. This means the machine will not automatically start up after a power cut or switching on of the power supply, unless you first reset the start switch.

### 17. Outdoor use

- Your machine should not be used outdoors.

### 18. Extension cables

- Whenever possible, the use of extension cables is not recommended. If the use of an extension cable is unavoidable, then it should have a minimum core cross section of 2.5 mm<sup>2</sup> and limited to a maximum length of 3 metres.
- Extension cables should be routed away from the direct working area to prevent a trip hazard.

### 19. Guard against electric shock

- Avoid body contact with earthed or grounded surfaces such as pipes and radiators. There is an increased risk of electric shock if your body is earthed or grounded.

### 20. Always work within the machine's intended capacities

- Operator safety and machine performance are seriously adversely affected if attempts to make the machine perform beyond its limits are made.

### 21. Do not abuse the power cable

- Never pull the power cable to disconnect it from the power socket. Always use the plug.
- Keep the power cable away from heat, oil and sharp edges.
- Do not use the power cable for carrying or moving the machine.

### 22. Secure the work piece

- Ensure that the work piece is securely held before starting to machine it.
- When working within 300 mm of the machining area, always use a push stick to feed the work piece in to the blade or cutting tool. The push stick should have a minimum length of 400 mm. If the push stick becomes damaged, replace it immediately.
- Use extra supports (roller support stands etc.) for any work pieces large enough to tip when not held down to the table top.

- Do not use another person as a substitute for a table extension, or as additional support for a work piece that is longer or wider than the basic table, or to help feed, support, or pull the work piece.
- Do not attempt to machine more than one work piece at a time.
- When feeding the work piece towards the blade or cutting tool never position your hands in direct line of the cutting path. Avoid awkward operations and hand positions where a sudden slip could cause your hand or fingers to move into the machining area.

### 23. Stay alert

- Safety is a combination of operator common sense and alertness at all times when the machine is being used.
- Use all machines with extreme care and do not use the machine when you are tired or under the influence of drugs, alcohol or medication.

### 24. Use the correct tool for the job

- Do not use the machine for any purpose other than which it was designed.
- When selecting replacement cutting tools and blades, always ensure that they are designed to cut the material that you intend to use them for. If in any doubt seek further advice from the manufacturer.

### 25. Connect dust extraction equipment

- Always use dust extraction equipment. The dust extractor should be of suitable size and capacity for the machine that it is connected to and have a filtration level appropriate to the type of waste being collected. Refer to the relevant section of the manual for details of the specific dust extraction requirements for this machine.
- The dust extractor should be switched 'ON' before starting the machine that it is connected to. The dust extractor should be left running for 30 seconds after the last machining operation is complete in order to clear any residual waste from the machine.

### 26. Ensure that the machine is correctly guarded

- Never use the machine if any of the standard safety guards and equipment are removed or damaged.
- Some machines incorporate safety interlocks to prevent the machine from being used without the guards in place. Never attempt to bypass or modify the interlocks to allow the machine to be used without the guards in place.

### 27. Maintain your machine with care

- This manual gives clear instructions on installation, set up and operation of the machine and also details any routine and preventative maintenance that should be performed periodically by the user.
- Remember always to switch off and unplug the machine from the power supply before carrying out any setting up or maintenance operations.
- Follow any instructions for the maintenance of accessories and consumables.
- Do not use compressed air to clean the machine. Always use a brush to dislodge dust in places that are awkward to reach and a dust extractor to collect the waste.
- Inspect electric cables periodically and, if damaged, have them replaced by an authorised service facility or qualified electrician.
- Inspect extension cables (if used) periodically and replace if damaged.

### 28. Keep cutting tools sharp and clean

- Correctly maintained cutting tools are easier to control and less likely to bind.
- Cutting tools and blades can become hot during use. Take extreme care when handling them and always allow them to cool before changing, adjusting or sharpening them.

### 29. Disconnect the machine from the power supply

- When not in use, before servicing, changing blades etc. always disconnect the machine from the power supply.

### 30. Check for damaged parts

- Before each use of the machine, it should be carefully checked to determine that it will operate properly and perform its intended function.
- Check for alignment of moving parts, binding of moving parts, breakage

## 2. General Health and Safety Guidance

of parts and any other conditions that may affect the operation of the machine.

- A guard or other part that is damaged should be properly repaired or replaced by a qualified person unless otherwise indicated in this instruction manual.
- Do not use the machine if the switch does not turn the machine 'ON' and 'OFF'.
- Have defective switches replaced by a qualified person.

### 31. Warning!

- The use of any accessory or attachment, other than those recommended in this instruction manual, or recommended by our Company may present a risk of personal injury or damage to the machine and invalidation of

the warranty.

### 32. Have your machine repaired by a qualified person

- This machine complies with the relevant safety rules and standards appropriate to its type when used in accordance with these instructions and with all of the standard safety guards and equipment in place. Only qualified persons using original spare parts should carry out repairs. Failure to do this may result in considerable danger to the user and invalidation of warranty.

### 33. Caution! Motor may become hot during use

- It is normal for motors on some machines to become hot to the touch during use. Avoid touching the motor directly when in use.

## 3. Additional Health and Safety Guidance for Table Saws

### Safe Operation

#### 1. Familiarise yourself with the machine

- Machining operations using circular saws have a history of serious accidents. Many of these result in the loss of fingers due to inadequate or missing guards. Many of these accidents could have been avoided by having correctly adjusted blade guards and using a push stick. Other minor accidents occur whilst setting, cleaning, adjusting or maintaining the machine.
- The machine is designed for cutting wood and composite board (plywood, MDF etc.). Certain plastics can also be cut using a suitable blade.

#### 2. Before switching the machine 'ON':

- Set the cutting height of the blade to ensure that the teeth of the blade protrude through the top of the work piece.
- If a beveled cut is required, set the blade to the required angle.
- Adjust the fence to correctly accommodate the size of work piece to be cut.
- Check that the riving knife is correctly aligned with the blade and that the fixings are fully secure.
- If the cut requires the use of a sliding table (where fitted), check that the sliding table has sufficient travel to complete the cut that you intend to make and that its travel is not limited by any surrounding objects in the work area.
- Check that the blade guard is not damaged. Replace a damaged guard immediately. Ensure that the blade guard is correctly positioned and that the fixings are fully secure.
- Check that the table insert is correctly fitted and not showing signs of damage or wear. Replace a defective table insert immediately.
- Check the condition of the blade to ensure that no teeth are missing or damaged and that the blade is not deformed, cracked or split. If any of these conditions apply, replace the blade immediately.
- Check that the saw blade is within the minimum and maximum diameters permissible on the machine as detailed in the manual.
- Check that the bore of the saw blade matches the diameter of the spindle of the machine. Never attempt to modify the saw blade to make it fit the machine.
- Check that the saw blade has a speed rating higher than 5000 rpm and complies with BS EN847-1.
- Check that the blade type and tooth pattern is suitable for the material to be cut.

#### 3. Whilst machining:

- Do not apply sideways pressure to the blade.
- Take particular care when cutting wood with knots, nails or cracks in it, or dirt on it. There is an increased risk of kick back where any of these conditions are present.
- Do not attempt to adjust or remove the riving knife or blade guard whilst the machine is running.
- Do not attempt to use the machine without the blade guard and riving knife in place.
- Do not attempt to cut free hand. Always use the fences supplied with the machine to support the work piece.
- When machining small workpieces always use a push stick to reduce the risk of injury.

#### 4. Maintenance

- Regularly check the condition and function of the blade guard, riving knife, fences and any work clamps. Replace any damaged or faulty components immediately.
- Clean the table surface to remove any deposits of resin and apply a suitable lubricant (silicone wax or spray) to help the work piece slide freely.

5. This machine falls under the scope of the 'Health and Safety at Work etc. Act 1974', and the 'Provision and Use of Work Equipment Regulations 1998'. In addition the elimination or control of risks from wood dust is included in the above regulations and the 'Control of Substances Hazardous to Health (COSHH) Regulations 2002'. We recommend that you study and follow these regulations.

Further guidance is available from The Health and Safety Executive and their website [www.hse.gov.uk](http://www.hse.gov.uk).

# 4. Record Power Guarantee

“**Products**” means the Products sold by Record Power subject to these terms and conditions;

“**Record Power**” is Record Power Limited, whose company registration number is 4804158 and registered office address is Centenary House, 11 Midland Way, Barlborough Links, Chesterfield, Derbyshire S43 4XA and sells through a network of Authorised Dealers;

“**Authorised Distributor**” is the nominated importer for your region who will generally sell through a network of Authorised Dealers. Details of Authorised Distributors for specific countries can be found in the Product manual or at [www.recordpower.info](http://www.recordpower.info);

“**Authorised Dealer**” is a retailer or business authorised to sell Record Power Products to end users.

## 1 Guarantee

- 1.1 Record Power guarantees that for a period of 5 years from the date of purchase the components of qualifying Products (see clauses 1.2.1 to 1.2.9) will be free from defects caused by faulty construction or manufacture.
- 1.2 During this period Record Power, its Authorised Distributor or Authorised Dealer will repair or replace free of charge any parts which are proved to be faulty in accordance with paragraphs 1.1 above provided that:
  - 1.2.1 you follow the claims procedure set out in clause 2 below;
  - 1.2.2 Record Power, our Authorised Distributor or Authorised Dealer are given a reasonable opportunity after receiving notice of the claim to examine the Product;
  - 1.2.3 if asked to do so by Record Power, its Authorised Distributor or Authorised Dealer, you return the Product, at your own cost, to Record Power’s premises or other approved premises such as those of the Authorised Distributor or supplying Authorised Dealer, for the examination to take place;
  - 1.2.4 the fault in question is not caused by industrial use, accidental damage, fair wear and tear, wilful damage, neglect, incorrect electrical connection, abnormal working conditions, failure to follow our instructions, misuse, or alteration or repair of the Product without our approval;
  - 1.2.5 the Product has been used in a domestic environment only;
  - 1.2.6 the fault does not relate to consumable Products such as blades, bearings, drive belts or other wearing parts which can reasonably be expected to wear at different rates depending on usage (for full details contact Record Power or your local Authorised Distributor);
  - 1.2.7 the Product has not been used for hire purposes, by you or by a previous owner;
  - 1.2.8 the Product has been purchased by you as the guarantee is not transferable from a private sale.
  - 1.2.9 where the Product has been purchased from a retailer, the 5 year guarantee is transferable and begins on the date of the first purchase of the Product and in the event of a claim under this guarantee proof of the original purchase date will be required to validate the warranty period.

## 2 Claims Procedure

- 2.1 In the first instance please contact the Authorised Dealer who supplied the Product to you. In our experience many initial problems with machines that are thought to be due to faulty parts are actually solved by correct setting up or adjustment of the machines. A good Authorised Dealer should be able to resolve the majority of these issues much more quickly than processing a claim under the guarantee.
- 2.2 Any damage to the Product resulting in a potential claim under the guarantee must be reported to the Authorised Dealer from which it was purchased within 48 hours of receipt.
- 2.3 If the Authorised Dealer who supplied the Product to you has been unable to satisfy your query, any claim made under this Guarantee should be made directly to Record Power or its Authorised Distributor (for details of the Authorised Distributor in your country please see your Product manual or check [www.recordpower.info](http://www.recordpower.info) for details). The claim itself should be made in a letter setting out the date and place of purchase, and giving a brief explanation of the problem which has led to the claim. This letter should then be sent with proof of the purchase date (preferably a receipt) to Record Power or its Authorised Distributor. If you include a phone number or email address this will help to speed up your claim.
- 2.4 Please note that it is essential that the letter of claim reaches Record Power or its Authorised Distributor on the last day of this Guarantee at the latest. Late claims will not be considered.

## 3 Limitation of Liability

- 3.1 We only supply Products for domestic and private use. You agree not to use the Product for any commercial, business or re-sale purposes and we have no liability to you for any loss of profit, loss of business, business interruption or loss of business opportunity.
- 3.2 This Guarantee does not confer any rights other than those expressly set out above and does not cover any claims for consequential loss or damage. This Guarantee is offered as an extra benefit and does not affect your statutory rights as a consumer.

## 4 Notice

This Guarantee applies to all Products purchased from an Authorised Dealer of Record Power within the United Kingdom of Great Britain and Northern Ireland. Terms of Guarantee may vary in other countries – please check with the Authorised Distributor in your country (details of the Authorised Distributor for your country can be found in the manual or at [www.recordpower.info](http://www.recordpower.info)).

# 5. Specifications

**Motor input P1:** 3 kW  
**Motor output P2:** 2.5 kW  
**Scoring blade motor input P1:** 0.75 kW  
**Scoring blade motor output P2:** 0.55 kW  
**Motor speed:** 2800 rpm  
**Main blade diameter:** 315 mm  
**Blade bore:** 30 mm  
**Main blade speed:** 4500 rpm  
**Scoring blade diameter:** 120 mm  
**Scoring blade bore:** 20 mm  
**Scoring blade speed:** 8000 rpm  
**Blade Tilt:** 0-45°  
**Maximum depth of cut at 90°:** 95 mm

**Maximum depth of cut at 45°:** 67 mm  
**Maximum rip capacity:** 900 mm  
**Main table size:** 800 x 530 mm  
**Sliding carriage stroke:** 1200 mm  
**Right-hand extension table size:** 800 x 470 mm  
**Dust extraction outlet:** 100 mm  
**Full load current:** 17 A  
**Weight:** 354 kg  
**Table height from floor:** 870 mm  
**Sound pressure level** No load < 80.4 dB (A)  
Load < 85.7 dB (A)  
**Sound power level** No load < 98.1 dB (A)  
Load < 100.7 dB (A)

# 6. Getting to Know the TS2

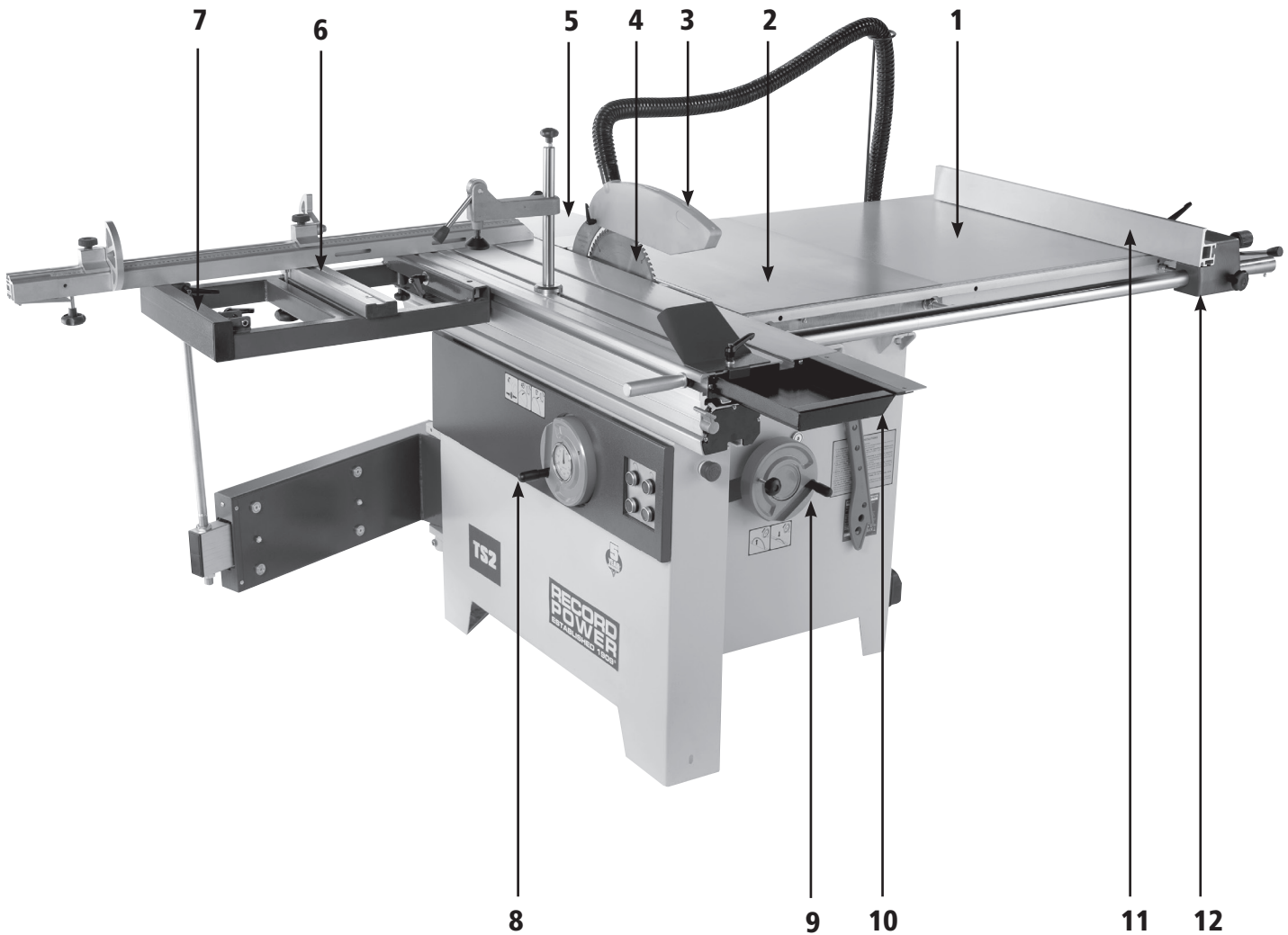

- 1 Right-hand extension table
- 2 Main table
- 3 Blade guard
- 4 Main blade
- 5 Rear extension table
- 6 Telescopic fence
- 7 Squaring frame
- 8 Blade angle adjustment hand wheel
- 9 Blade height adjustment hand wheel
- 10 Sliding carriage
- 11 Rip fence
- 12 Rip fence mount



# 7. Contents of the Package

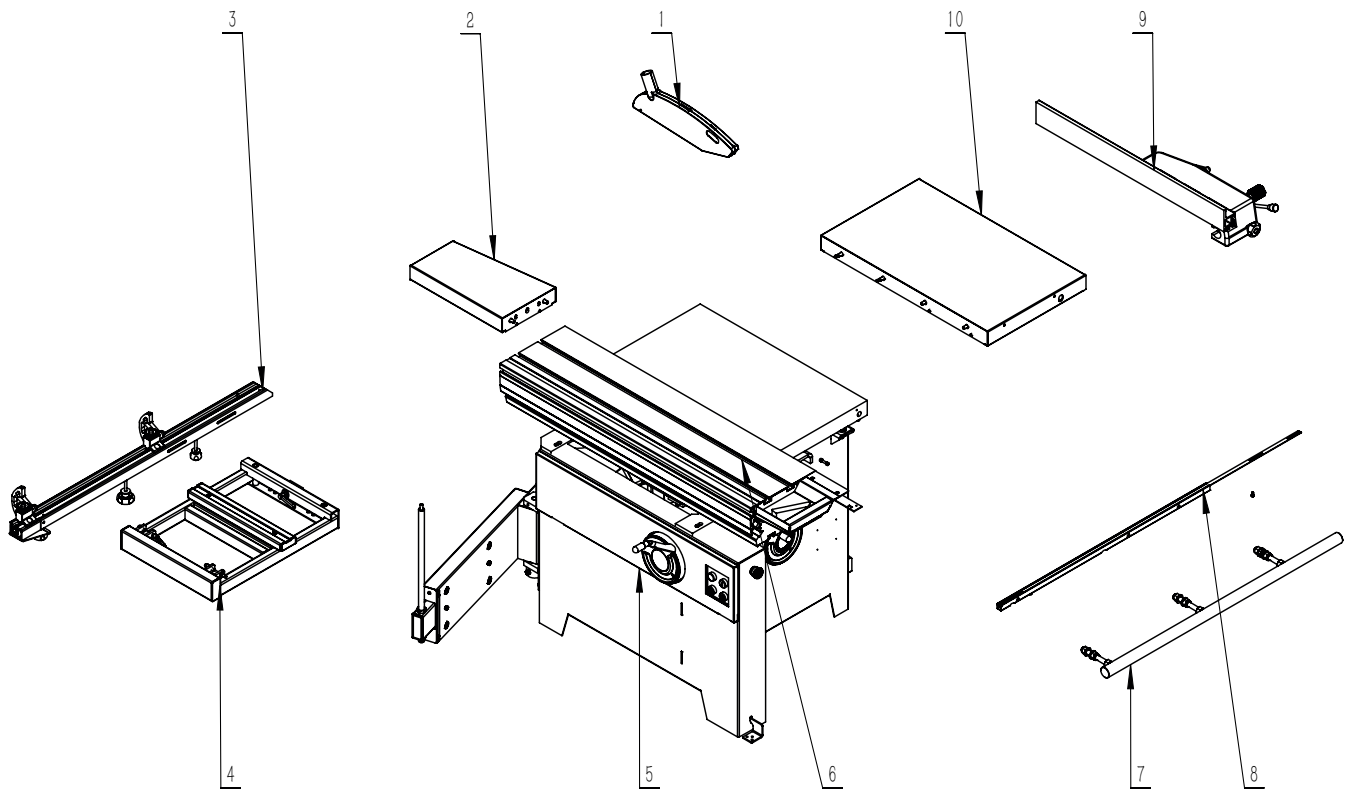

- 1 Blade guard
- 2 Rear extension table
- 3 Telescopic fence
- 4 Squaring frame
- 5 Frame assembly
- 6 Sliding carriage

- 7 Guide rail
- 8 Scale seat
- 9 Rip fence assembly
- 10 Right hand extension table

# 8. Assembly



**Warning: Lifting and handing should only be carried out by skilled personnel specially trained to execute this kind of operation. Make sure no one is standing under the overhung load and/or within the bridge crane working range during machine lifting and handing.**

Lifting may be carried out by bridge crane or self-propelled lift truck. Before moving the table saw remove all packaging from the machine and ensure no parts are loose. Check that the capacity of the lifting equipment is adequate for the gross weight of the machine as indicated in **Fig 8.1**.

If hoisting is carried out with a lift truck proceed as follows:

Adjust the width of the forks to 550 mm.

Insert forks as shown in **Fig 8.1**, ensuring that these are wedged against the back of the rear feet.

If a bridge crane or crane is to be used, proceed as follows:

Provide two slings of suitable length and capacity (belts minimum length 4000 mm).

Lift the slings and position them as shown in **Fig 8.1**.

Fasten the slings to the bridge crane having adequate lifting power.

Move the bridge crane by small steps to allow the slings to settle, until optimum stability conditions are achieved.

Lift carefully and slowly, without causing the load to swing and place the machine in the selected position.

Remove the protective wax coat from all tables and unpainted surfaces using kerosene or its derivative products. Do not use any solvent, petrol or gas oil, which might dull the paint or oxidise machine parts.

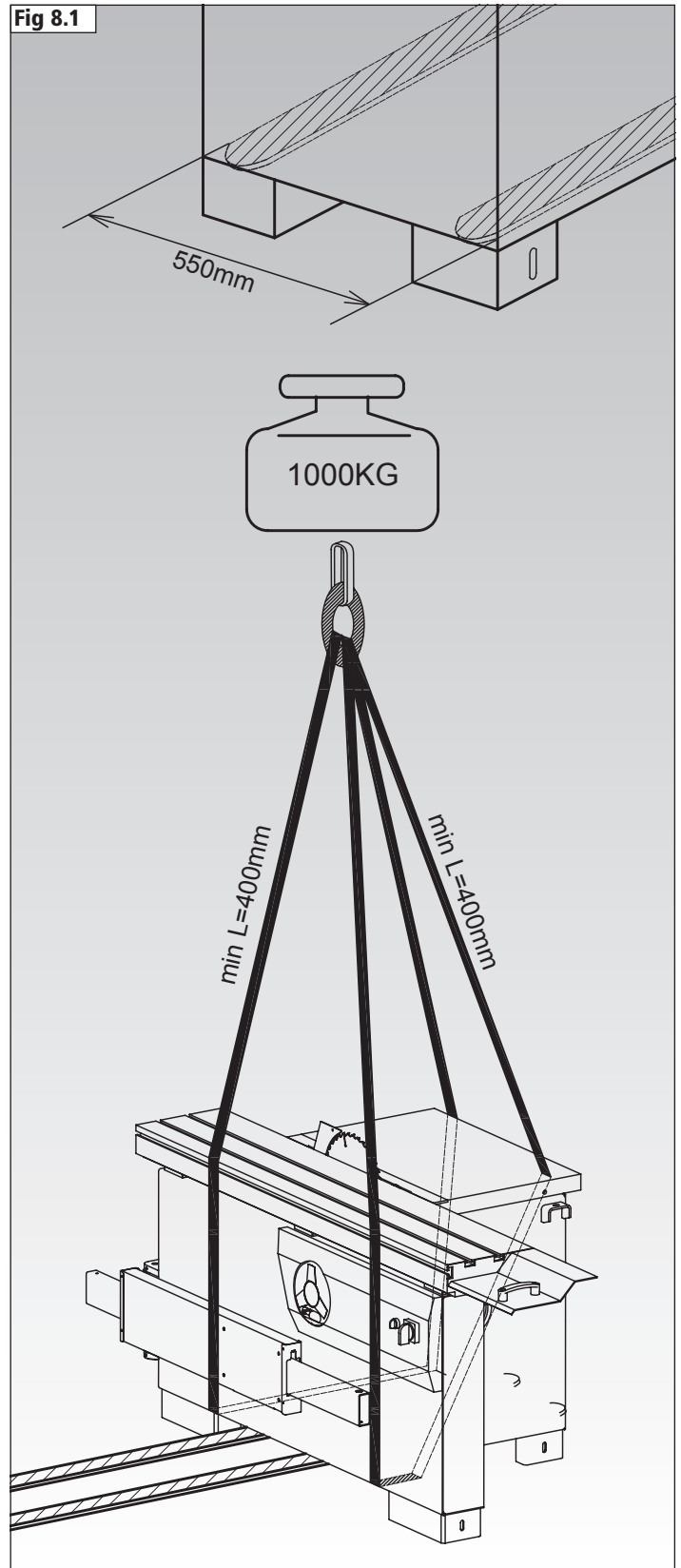

# 8. Assembly

## Fixing to the Floor

The machine must be fixed to the floor before use.

To fix the machine to the floor, use the supplied 4 x M10 Hex bolts and nut to adjust the feet and ensure machine is level, as shown in **Fig 8.2**.



**Tighten all bolts and nuts fully to avoid instability of machine or danger to the user.**

## Installation of the Extension Tables

First, attach the right hand extension table to the main table parallel to the blade, **Fig 8.3**. Attach with use of the 4 x M8 hex bolts and washers into the holes on the underside of the table. Then, attach the 4 M6 socket head cap screws and nuts for micro-adjustment into the remaining holes, as shown in **Fig 8.4**.

In the same way, attach the rear extension table to the main table at the rear of the blade with use of 2 M8 hex bolts and washers into the holes, followed by the 2 M6 socket head cap screws for micro-adjustment, to appear as shown in **Fig 8.5**.

## Installation of the Blade Guard

Attach the blade guard by aligning the holes in the blade guard and riving knife, **Fig 8.6**.

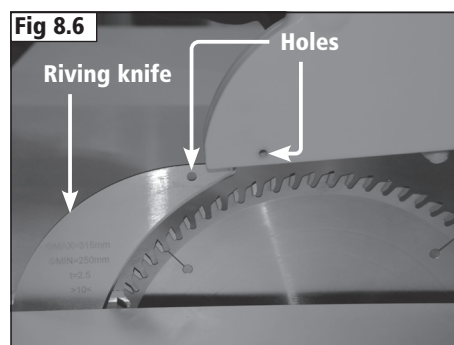
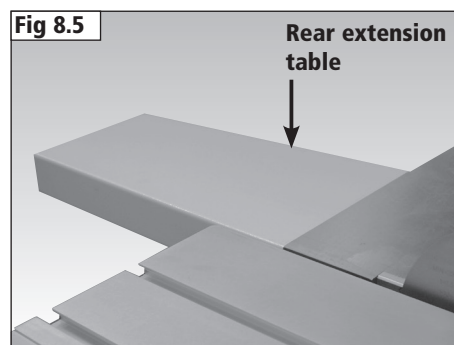
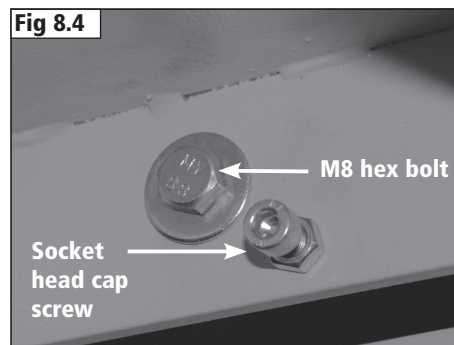
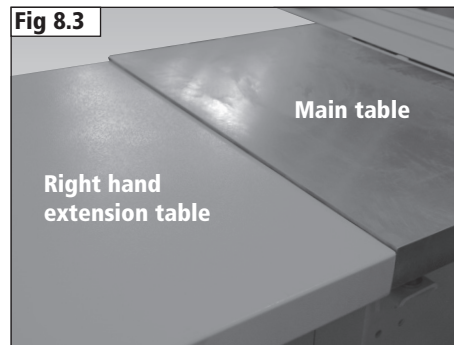
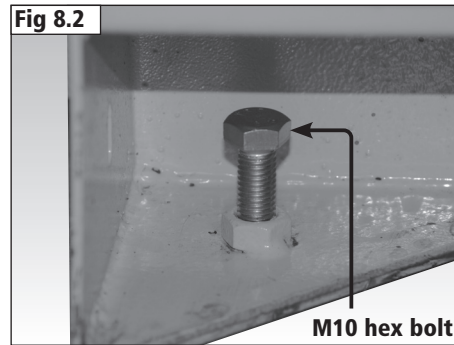

# 8. Assembly

Next, use the supplied M6 coach bolt and M6 ratchet handle to attach, as shown in **Fig 8.7**.

### Installation of Extraction Hose Support

To install the extraction hose support rod, first attach the 2 screw nuts and washers using M8 nuts into right hand extension table, using the holes as shown in **Fig 8.8**.

Next, feed the support rod through the 2 screw nuts and fully tighten the M8 screws nuts using a 3 mm hex wrench, to appear as shown in **Fig 8.9 A**. Once secure, thread the hose through the loop fitted to the extraction support, as shown in **Fig 8.9 B**.

### Fixing the Extraction Hose to the Blade Guard

To fit the extraction hose to the blade guard, attach the hose onto the outlet located at the top of the blade guard and secure in place with use of a jubilee clip, **Fig 8.10**

### Installation of the Squaring Frame

Before proceeding to attach the squaring frame to the sliding carriage, first attach the large ratchet handle, washer and sliding block to the squaring frame using the hole located on the side of the squaring frame, as shown in **Fig 8.11**.

**Note:** Ensure that the ratchet handle is positioned on the inside and the sliding block is positioned on the outside of the squaring frame.



**Do not fully tighten to allow movement to thread onto sliding carriage.**

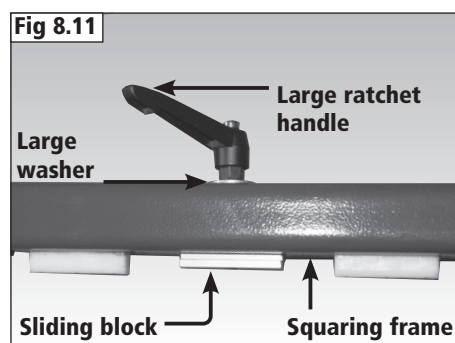
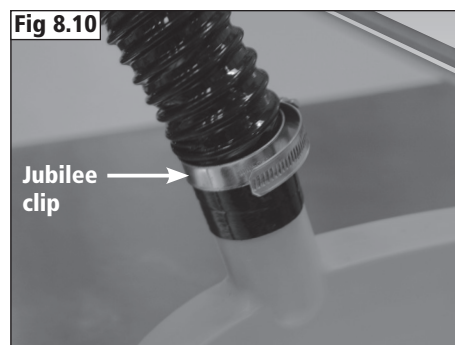
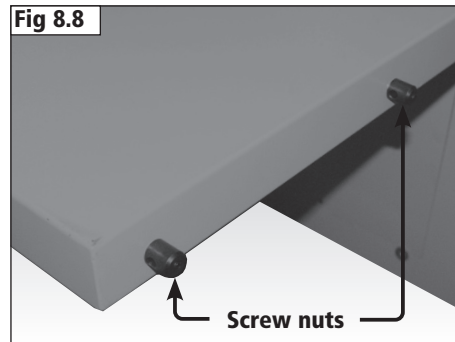
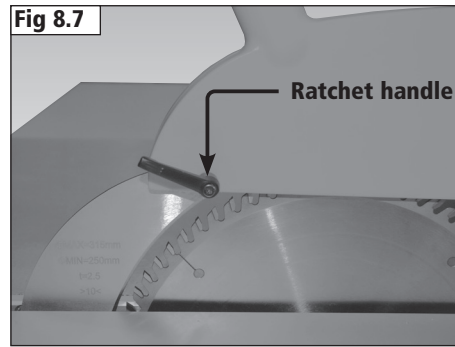

# 8. Assembly

Next, place the squaring frame onto the pre-installed support rod on the extendable arm with use of the hole on the underside of the squaring frame, **Fig 8.12**.

Once the support rod has taken the weight, attach the squaring frame to the sliding carriage by inserting the sliding block on the outside of the squaring frame into the 'T' slot on the side of the sliding carriage, **Fig 8.13**. Once the squaring frame is attached, fully tighten with the ratchet handle.

### Installation of the Telescopic Fence

To install the telescopic fence, thread the pre-installed pins through the hole and slot on the squaring frame, as shown in **Fig 8.14**. In the same movement, ensure that the telescopic fence block on the underside of the fence is fitted into the pre-set adjustable stop slot located to the left hand side of the squaring frame (supplied bolt on the adjustable stop slot is pre-set at 90°), as shown in **Fig 8.15**. Once in position, secure in place using the ratchet handle.

Next, attach the small and large star knobs to the underside of the pre-installed pins to secure in the telescopic fence in position, **Fig 8.16**.

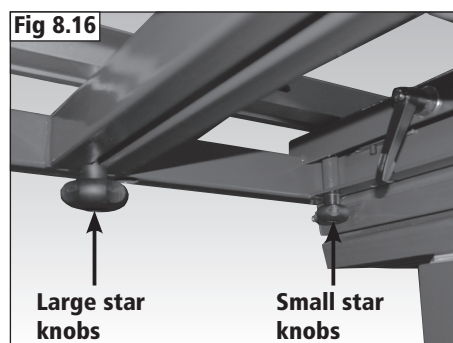
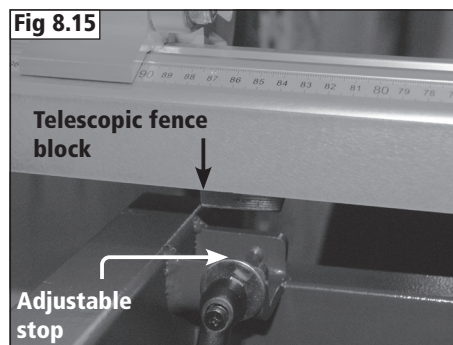
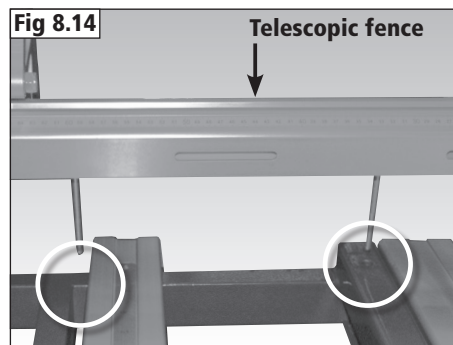
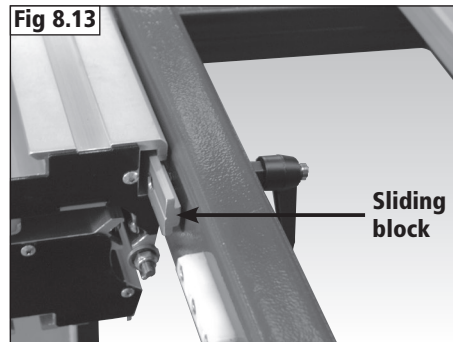
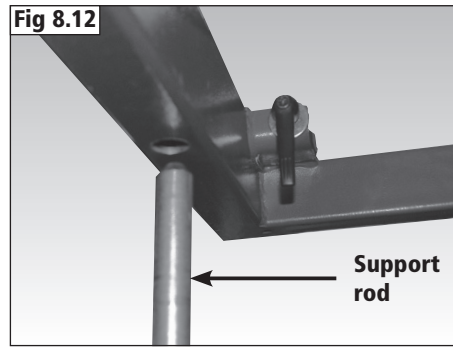

# 8. Assembly

## Adjusting the Angle of the Telescopic Fence

To adjust the angle of the telescopic fence, first release the telescopic fence block from the squaring frame using the ratchet handle on the squaring frame and lift from the slot. Next, use the angle scale to find the desired angle required, then bring the left-hand side of the fence towards the front of the blade, as shown in **Fig 8.17**.

Once the fence is positioned at the desired angle, secure in position by tightening the small and large star knobs, **Fig 8.16**.

This can be repeated at the front of the squaring frame if required.

## Extending the Telescopic Fence

To extend the telescopic fence, loosen the pre-installed star knob on the underside of the left-hand side of the telescopic fence, Fig 8.18. Pull out the fence extension from main fence structure to extend the capacity, as shown in **Fig 8.19**. The telescopic fence extension will enable support up to 1500 mm.

Once loosened, then, pull out the fence extension from main telescopic fence structure to extend the fence capacity, as shown in **Fig 8.19**. The telescopic fence extension will enable support of up to 1500 mm.

## Installation of the Support Tray

To install the support tray, first remove the 3 M6 screws from the sliding carriage extrusion using the 3 mm hex wrench, **Fig 8.20**.

Offer the support tray up to the sliding carriage extrusion, aligning the 3 holes within the sliding carriage with the 3 cut out areas in the support tray. Then, attach the support tray to the sliding carriage by re-attaching the 3 M6 screws through the cut out areas in the support tray, as shown in **Fig 8.21**.

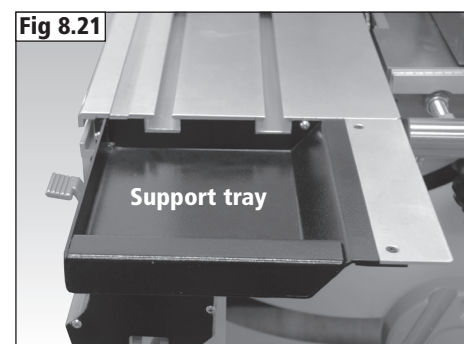
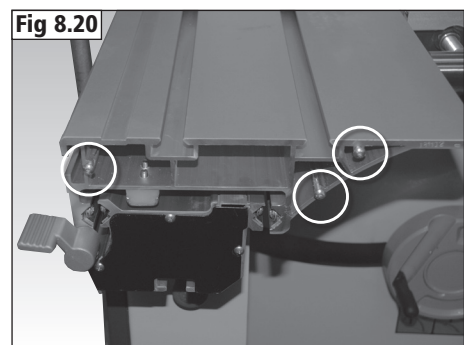
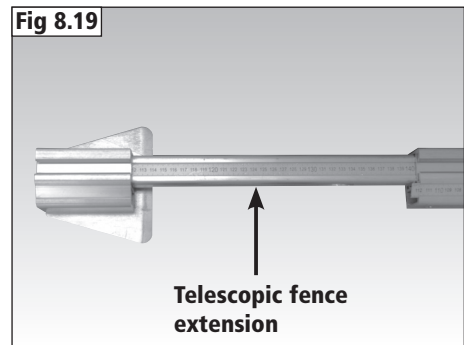
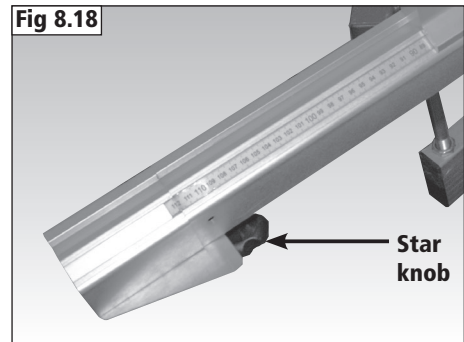
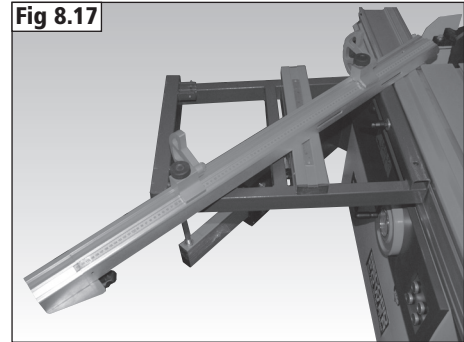

# 8. Assembly

## Attaching the Sliding Carriage Handle

To fit the sliding carriage handle, first insert the large bolt into the 'T' slot located at the right-hand side of the sliding carriage. Then, screw the sliding carriage handle into the large bolt and fully tighten to secure in position, **Fig 8.22**.

## Aligning the Extension Tables Flush with the Main Table

To ensure that both the right-hand extension table and the rear extension table are correctly aligned with the main table, use a straight edge and feeler gauge to check the flatness, **Fig 8.23**.

If adjustment is required, loosen the socket cap head screws on the underside of both the right-hand and rear extension tables to micro adjust, **Fig 8.24**. Once the tables are correctly aligned, re-tighten to secure in place.

## Installation of the Fence Rail and Scale

To install the fence rail and scale, first unscrew the M5 cap head screw attached to the scale seat to allow the scale to be fully fed into the scale seat. Next, feed the scale into the scale seat 'T' slot and secure in place by re-tightening the the M5 cap head screw, **Fig 8.25**.

Then, attach the scale seat and scale to the main table and right-hand extension table with use of the 3 supplied M5 cap head screws, by inserting through the holes within the scale seat and both tables, then fully tighten, **Fig 8.26**.

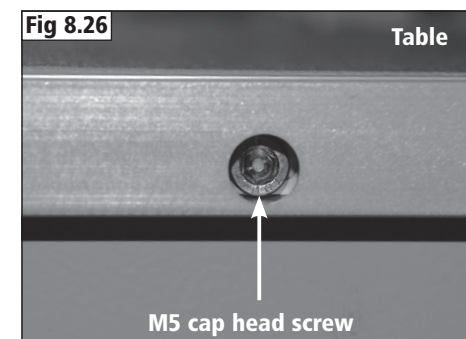
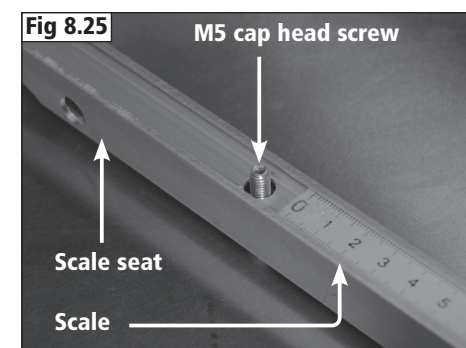
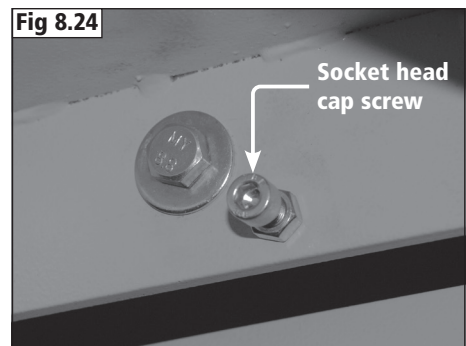
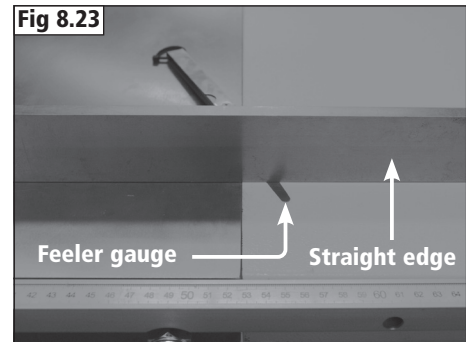
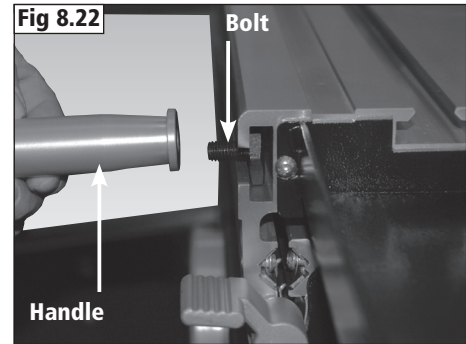

# 8. Assembly

To attach the fence rail, first remove the pre-installed M15 locking nuts and large washers from the connecting rods attached to the fence rail, as shown in **Fig 8.27**.

Next, thread the 3 connecting rods on the fence rail through the holes on the main table and right-hand extension table, **Fig 8.28**.

Once in position, attach the washers followed by the M15 locking nuts using a 24 mm wrench (not supplied) to the connecting rods on the underside of the table, as shown in **Fig 8.29**.



**Ensure that the right-hand extension table is correctly aligned with the main table to allow the fence rail to fit correctly.**

### Alignment of the Fence Rail with the Main Table and Right-Hand Extension Table

To align the fence rail to the main table and right-hand extension table, measure the distances between the fence rail and both the main and right-hand extension tables and do so at both ends of the fence rail, **Fig 8.30**. If the measurements are un-equal, adjust the fence rail accordingly by loosening the M15 locking nut on the underside of the table to allow the required movement to adjust, **Fig 8.29**.

### Installation of the Rip Fence

To install the rip fence, first remove the pre-installed M4 cap head screw from the underside of the fence rail using a 4 mm hex wrench, as shown in **Fig 8.31**.

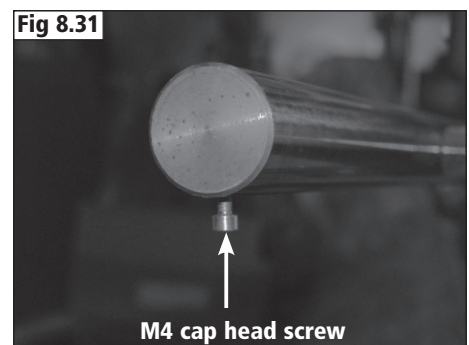
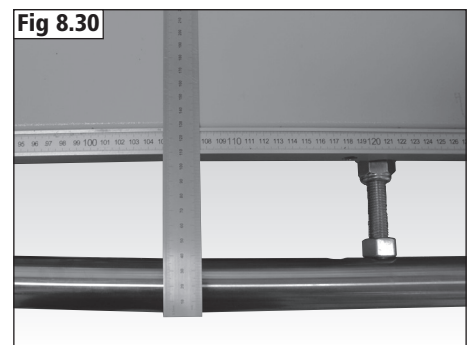
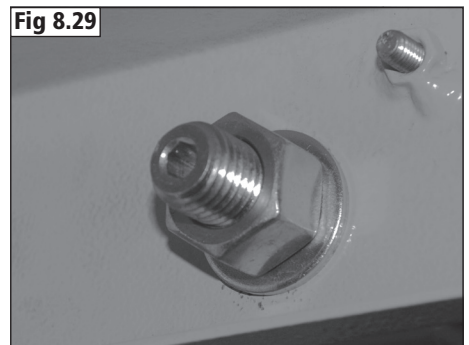
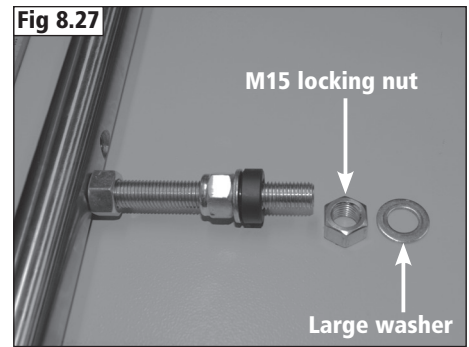



# 8. Assembly

Next, slide the rip fence mount onto the fence rail ensuring that the cam action locking lever is in the released position to allow free movement along the fence rail, **Fig 8.32**.

### Attaching the Rip Fence to the Rip Fence Mount

To attach the rip fence to the rip fence mount, use the 'T' slot in the rip fence and slide onto the pre-installed sliding block located on the left side of the rip fence mount, as shown in **Fig 8.33**.

Once in position, secure in place using the fence mount ratchet handle, **Fig 8.32**.

**NOTE: Ensure that the cam locking lever is in locked position before making making micro-adjustments.**

### Adjusting the Rip Fence

To micro-adjust the rip fence, rotate the micro adjustment handle, **Fig 8.34**.

To move the rip fence right (away from the blade), rotate the micro-adjustment handle clockwise.

To move the rip fence left (towards the blade), rotate the micro-adjustment handle anti-clockwise.

### Alignment of the Rip Fence to the table

To align the rip fence to the table, first use a square to ensure that the rip fence is at 90°, as shown in **Fig 8.35**. If adjustment is required, loosen the M15 locking nut on the underside of the table using a 24 mm wrench (not supplied) and adjust the fence rail.

### Alignment of the Rip Fence to the Blade

To correctly align the rip fence to the blade, first mark out a measurement point on one of the blade teeth using a marker pen, **Fig 8.36**. Once a measurement point has been marked out, ensure that the marked out tooth is positioned at the front of the blade and is adjacent to the table surface.

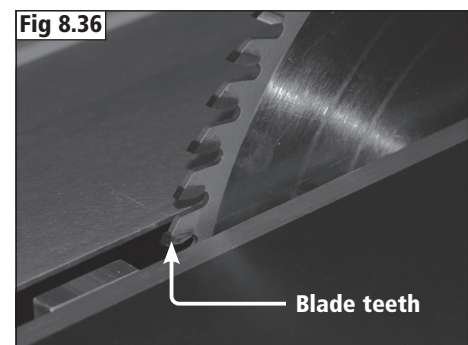
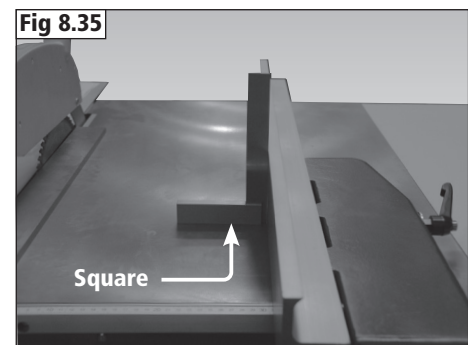
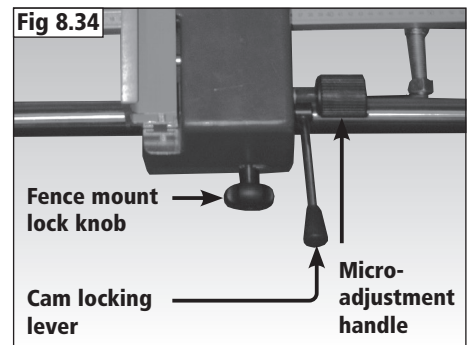
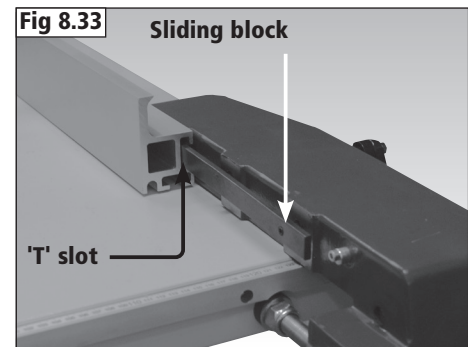
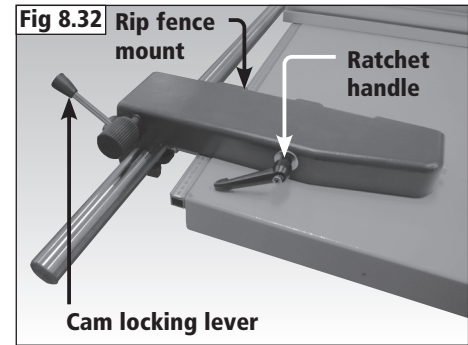

# 8. Assembly

Next, bring the rip fence close to the blade. Using a ruler measure from the previously marked blade tooth to the rip fence, **Fig 8.37**.

Once the first measurement has been taken, rotate the blade with a half-turn so that the marked area is at the rear (as in first measurement, ensure that the marked area is adjacent to the table). Next, measure in the same way.

If adjustment is required, loosen the M15 lock nuts attached to the fence rail located on the underside of the table using a 24 mm hex wrench (not supplied) and adjust accordingly.

Once both the top and bottom measurements are equal, the rip fence will be correctly aligned in relation to the blade.

## Installation of the Optional Clamp Support to the Sliding Carriage

To attach the optional clamp support to the sliding carriage, slide the sliding block located at the bottom of the clamp support into either of the 2 'T' slots located to the rear of the blade on the sliding carriage, as shown in **Fig 8.38**.

Once attached, rotate the entire clamp structure to secure in place, **Fig 8.39**.

## Installation of Optional Press Plate

To install the optional press plate, insert the sliding block located at the bottom of the press plate, into either of the 2 'T' slots on the sliding carriage to the front of the blade, **Fig 8.40**. Once in position, secure in place using the ratchet handle.

Ensure that the press plate is fitted as shown in **Fig 8.41** to help support the work piece when cutting.

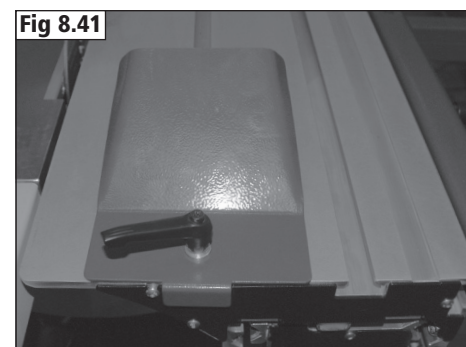
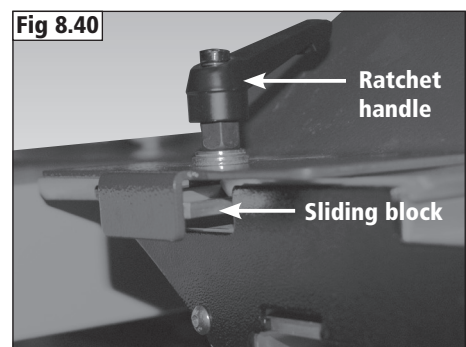
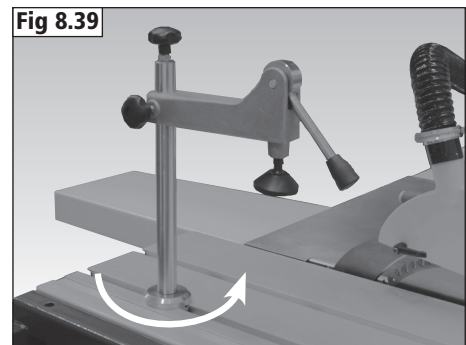
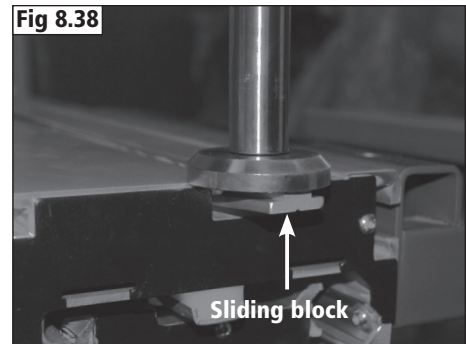
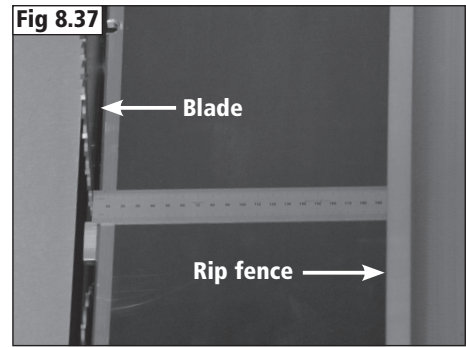

# 8. Assembly

## Adjusting the Position of the Sliding Carriage

To adjust the position of the sliding carriage, use the pre-installed locking lever located on the side of the sliding carriage, **Fig 8.42**. To lock the sliding carriage in a fixed position, pull the locking lever up. To lock the sliding carriage push the locking lever down.

The sliding carriage is lockable in a number of different positions for stability and support when cutting, as shown in **Fig 8.43**. Once the sliding carriage is in the desired position, secure in place using the locking lever, **Fig 8.42**.

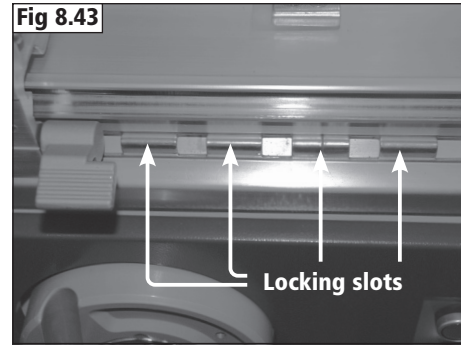
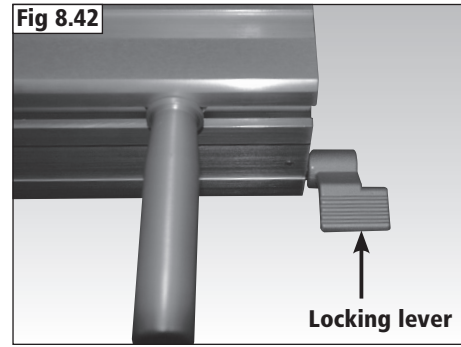

# 9. Operation



**Warning: Always operate the table saw with suitable dust extraction equipment attached.**

Suitable dust extraction greatly reduces the risk of dust inhalation and aids better functioning of the machine. The table below lists the minimum air flow and speed values referenced to each extraction operation. The related pressure drop at the dust port is 530 Pa.

**Upper hood:** Air flow 140 M<sup>3</sup> / hour

**Lower hood:** Air flow 690 M<sup>3</sup> / hour

**Minimum air speed:** 20 m / s

Ensure that the dust extraction system guarantees these values at the connection point.

**Blade guard extraction port diameter:** 32 mm

**Main body extraction port diameter:** 100 mm

Ensure the extraction hoses are connected correctly to the machine and that their position does not obstruct the operator.

## Safety Features

The machine is equipped with a safety micro switch, as shown in **Fig 9.3**. This switch stops the machine if the blade cover is removed during operation.

## Emergency Switch

When the red button located on the side of the machine is pressed, see **Fig 9.4**, the power will be cut immediately. Reset the button by turning it clockwise to release.

## In the Event of a Blockage or if the Machine Stalls

If the machine stalls due to the blade becoming trapped in the work piece, switch it off immediately by pressing the red button located on the right hand side of the machine, as shown in **Fig 9.4**.

If the blade is trapped within the work piece, it may be necessary to prise the work piece apart slightly using a suitable lever in order to free the blade.

To re-start the machine, press the top left hand green button on the control panel to re-start the main blade, **Fig 9.5**.

To re-start the scoring blade, press the top right green button on the control panel, **Fig 9.5**.

## In the Event of a Power Failure

The table saw is fitted with a no volt release (NVR) switch to protect the user against automatic starting of the machine when power is restored after a power failure.

In the event of a power failure, first locate and rectify the source of the failure. If the fault is within the power circuit of the workshop, there may be an underlying cause (circuit overload etc.) that should be investigated by a qualified electrician, before attempting to restore the power source.

If a cutting operation was taking place when the power supply was interrupted, then it may be necessary to free the blade from the work piece before attempting to re-start the machine.

Once the power is restored, the machine can be re-started by pressing the green button located at the top left of the control panel as shown in **Fig 9.5**.

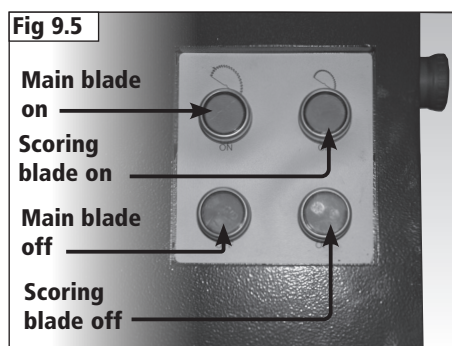
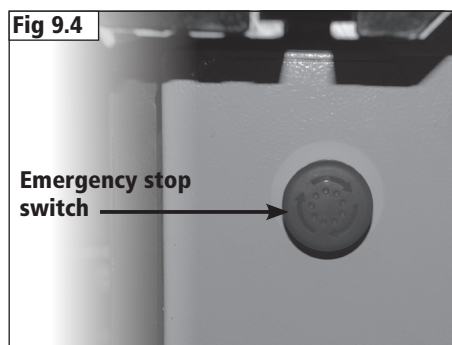
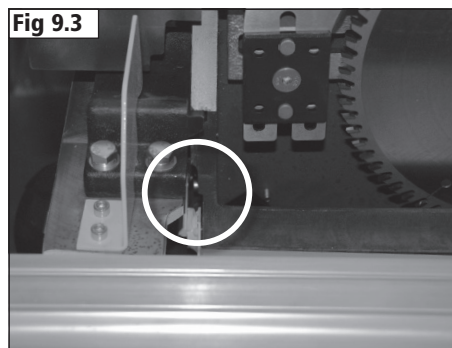
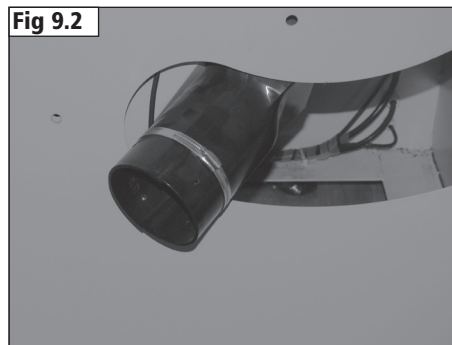
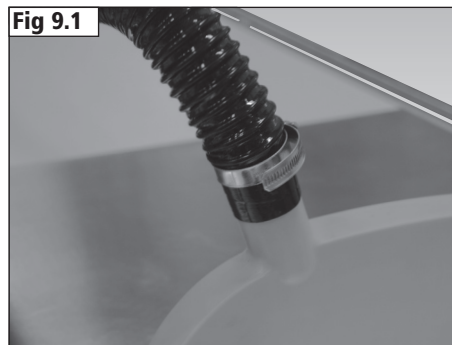

# 9. Operation



**Warning:** Before touching the blade ensure that the machine is switched off and isolated from the power supply. Wear protective gloves when handling the blade.

## Basic Circular Saw Principle

The blade rotates on a spindle, and breaks through the timber, cutting on a continuous stroke, **Fig 9.6**.

## Workpiece Support

Good workpiece support is essential when using a table saw. Additional supports should always be used if the workpiece overhangs the table. Roller stands are ideal for this purpose and should be used at both infeed and outfeed ends of the machine.

## Use of a Push Stick (Provided)

A push stick should always be used when making any cut less than 300 mm in length or when feeding the last 300 mm of a longer cut. The leading hand should never be closer than necessary to the front of the saw and hands should never be in line with the saw blade.

A push-stick should always be used to remove the cut piece from between the saw blade and fence.

## Setting the Blade Height

The blade height must be adjusted so the blade guard is no more than 5 mm higher than the timber and the teeth should also project through the top of the workpiece as in **Fig 9.7**. The blade height is controlled using the hand wheel on the right-hand side of the machine, **Fig 9.8**.

## Setting the Blade Angle

To tilt the blade in order to achieve a bevelled edge, turn the hand wheel on the control panel, **Fig 9.9**, until the blade is positioned as required.



## Cutting Guidelines

Do not remove the timber from the saw blade part way through a cutting operation. Always finish the cut for the safest operation and do not pull the timber back towards the operator whilst the blade is in motion.

If the timber becomes stuck, disconnect the machine from the power source before carefully removing it from the saw blade.

Never push the timber into the blade with great force. Feed the timber slowly and carefully. Harder and thicker timber will require a slower feed rate than soft or thin material.

Ensure the timber does not contain any metal objects such as screws or nails. If these come into contact with the blade, they could be thrown from it at great speed.

Always use a push stick in order to keep the hands as far away from the blade as practically possible.

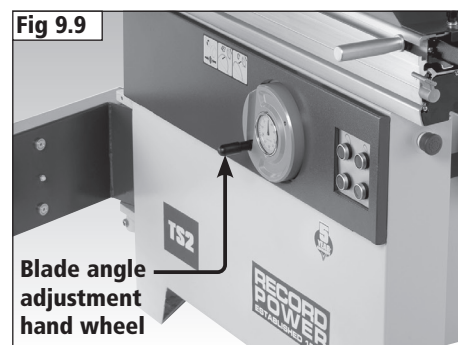
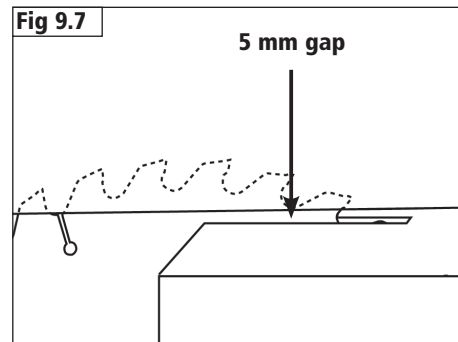
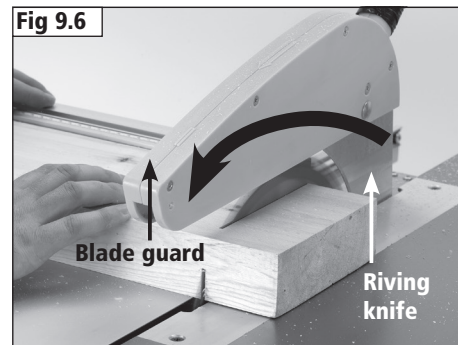

# 9. Operation



Never attempt to use the machine without the blade guard and riving knife in position. Always ensure that the blade guard and riving knife are correctly adjusted to suit the size and type of workpiece and that they are fully secured with the original fixings supplied. Both components are essential for safe use of the machine. The blade guard shields the blade from the operator during use and the riving knife ensures that the cut in the timber does not close as it passes beyond the blade, therefore reducing the risk of the timber binding to the blade.

## Working Position

The machine has been designed for use by only one person.

Please take note of the correct working position for different cutting operations as shown in **Fig 9.10**.

Position A – Parallel cutting using the rip fence.

Position B – Cross cutting or panel cutting using the sliding table.

## Cutting

The choice of cutting method depends on the dimensions of the wood to be machined and the type of machining to be carried out.

## Ripping

When the timber is to be cut with the grain, use the rip fence as shown in **Fig 9.11**. Lock the sliding carriage and keep the work piece against the rip fence, pushing it carefully towards the blade. Always use a push stick when feeding the work piece in to the blade or when clearing off cuts from the work area.

## Cross Cutting

When the timber is cut across the grain, use the and sliding carriage as shown in, **Fig 9.12**.

## Bevelled Edge

When an angle less than 90° is required to the work piece cut, tilt the blade as shown in **Fig 9.13**. When the rip fence is being used with the blade tilted, it should be used in the lower position to prevent it touching the blade and blade guard, **Fig 9.13**.

## Panel Sizing

When machining large panels, position the telescopic fence and the squaring frame as shown in **Fig 9.14**. In this position the maximum cutting length is obtained.

## First Cut

Slide the sliding beam as far forward (towards the front of the machine) as possible. Place the panel against the cross cut fence, set the cutting width by placing the panel against the cross cut fence flip-over stop and hold it in place with the clamp. Make the first cut along side 1.

## Second Cut

Turn the panel 90° counter-clockwise. Place the side previously cut against the cross cut fence, set the cutting width by placing the panel against the cross cut fence flip-over stop and hold it in place with the stop plate and cut side 2.

## Third Cut

Turn the panel 90° counter-clockwise. Place the side previously cut against the cross cut fence, set the cutting width by placing the panel against the cross cut fence flip-over stop and hold it in place with the stop plate and cut side 3.

## Fourth Cut

Turn the panel 90° counter-clockwise. Place the side previously cut against the cross cut fence, set the cutting width by placing the panel against the cross cut fence flip-over stop and hold it in place with the stop plate and cut side 4.

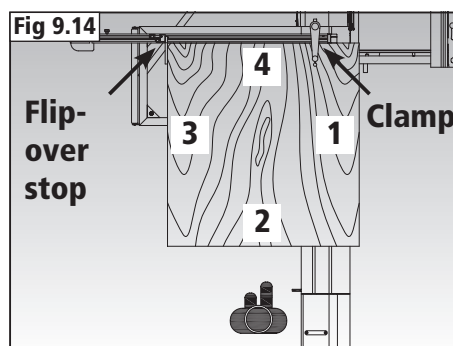
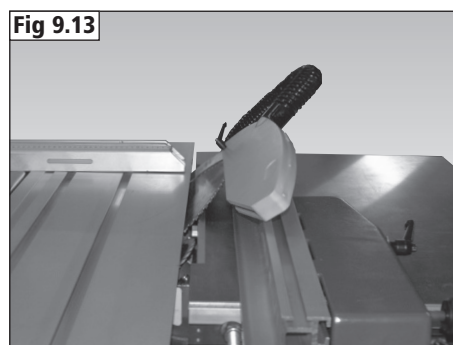
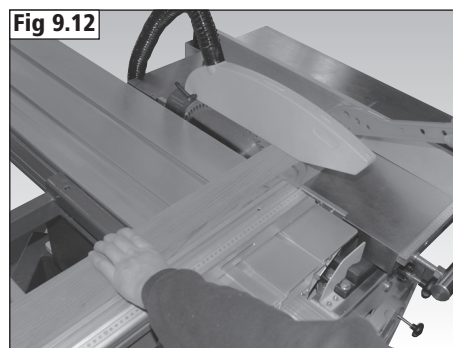
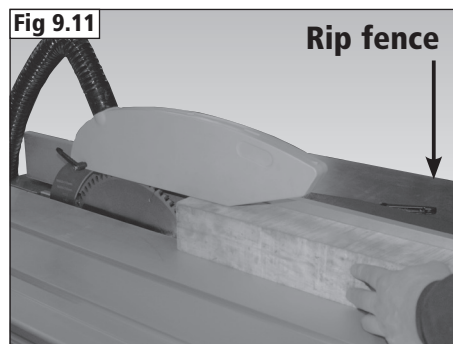
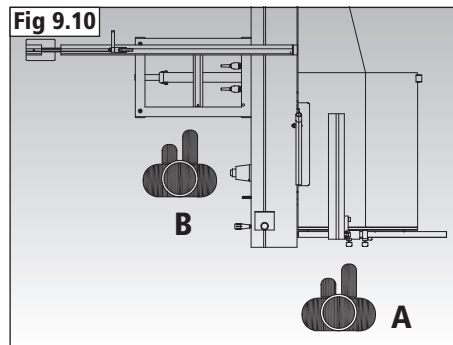

# 9. Operation

## Adjusting the Scoring Blade

When cutting laminated panels the scoring blade, **Fig 9.15**, should be used to ensure a clean cut. Position the scoring blade in order to have a cutting depth of 2 mm as shown in **Fig 9.15**.

To adjust the scoring blade height, loosen the scoring blade locking knob and rotate the scoring blade adjustment knob, **Fig 9.16**.

To adjust the scoring blade position, if necessary unlock the sliding carriage. Slide the sliding carriage all the way towards the rear of the main blade, allowing access to the underside of the main blade and scoring blade. Then, loosen the 2 scoring blade adjustment screws, using the 5 mm hex wrench, as shown in **Fig 9.17**. Then, using the 5 mm hex wrench rotate the shaft to re-position the scoring blade. Rotate the shaft clockwise to move the scoring blade left of the main blade and rotate the shaft anti-clockwise to move the scoring blade right of the main blade. Once desired position of the scoring blade is achieved, re-tighten the 2 scoring blade adjustment screws to secure in position.

## Kickback

Kickback can occur as the material passes through the saw blade. When the timber is past the centre point of the blade the teeth are moving upwards and towards the user, **Fig. 9.18**. If the timber closes onto these upward moving teeth, the timber may kickback.

The way to overcome kickback is to prevent the timber from closing up onto the blade. To do so, the fence must be set correctly. If the rip fence is placed with too much of it beyond the centre point of the blade, it can force the timber into the blade, causing kickback. By ensuring the fence is positioned fully in front of the centre point, **Fig 9.19**, the timber has space to move into as the cut is made. Kickback is now far less likely to occur as the timber isn't being forced into the upward moving blade.



**Please note: Ensure the rip fence is parallel to the main table and blade. If the rip fence is not parallel it can push the timber into the blade and this can also cause kickback.**

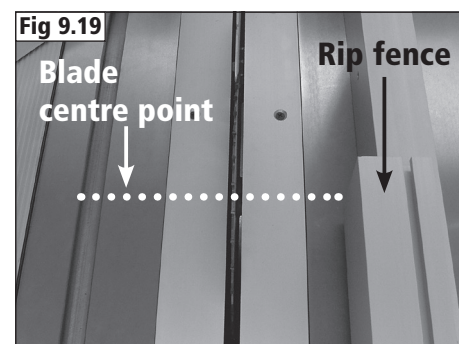
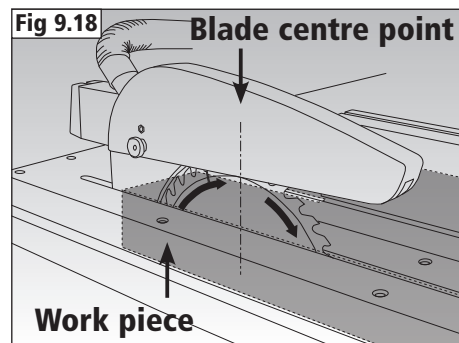
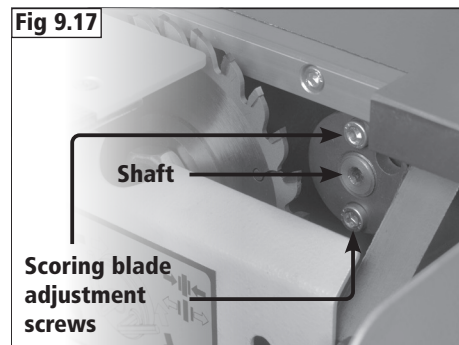
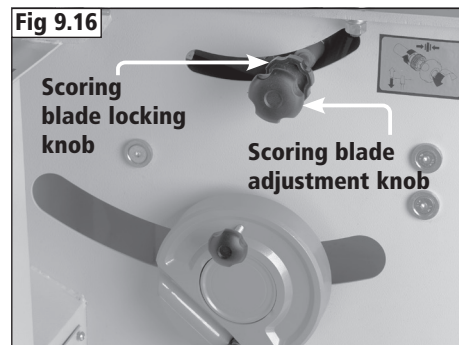
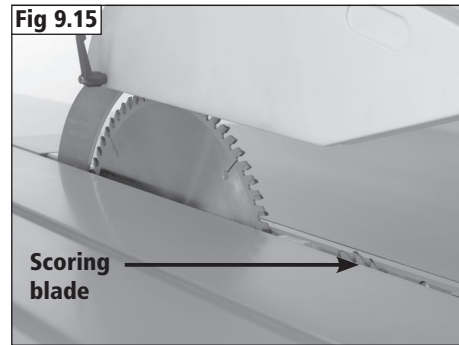

# 9. Operation

## Blade Selection

Before undertaking any application on a table saw is important to consider blade selection. There are many blade types available and it is important to select the right blade for each task. This machine is supplied with a good multi-purpose blade, but for specialist applications a blade with a different tooth pattern may be required.



When choosing a table saw blade always ensure that it is a hard bodied blade as soft bodied blades are only suitable for power tools. The easiest way to tell the difference between hard and soft bodied blades is that hard bodied blades have movement slots cut into the gullets of the blade, **Fig 9.20**, and soft bodied blades are solid, **Fig 9.21**.

The correct blade should be used for the type and thickness of material being cut. As a general rule, 2 to 3 teeth should cut at the same time, as shown in **Fig 9.22**. Where only 1 tooth cuts the work piece at a time as in **Fig 9.23**, the quality of finish will be adversely affected.

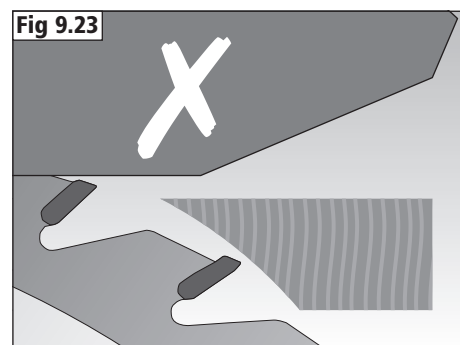
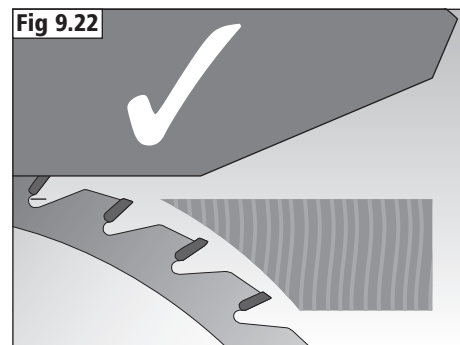
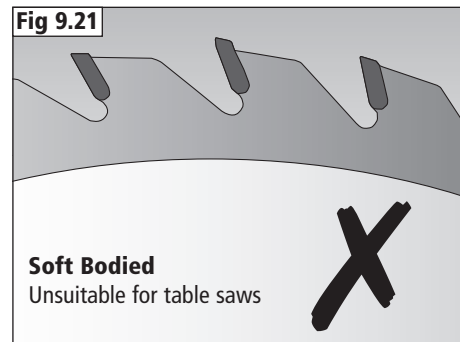
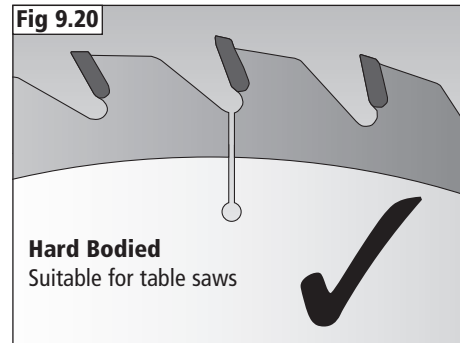



# 9. Operation

## Types of Blades and Their Teeth

### Rip Blade

These blades have flat topped teeth and lower tooth numbers for efficient and accurate ripping with minimal friction or burning that can be experienced with the wrong blade choice. **Fig 9.24.**

### General Purpose Blade

This blade has alternating top bevels on the teeth and is in the mid range of teeth per inch. This provides the best compromise to enable efficient rip cuts, cross-cutting of timber and for sizing plywood, chipboard and other wood based panels. If undertaking large volumes of ripping or cross-cutting, a dedicated blade will provide better performance but these are a good all-rounder for varied use. **Fig 9.25.**

### Cross-Cutting Blade

Can be alternating bevel (as per general purpose) or triple chip ground as shown for clean, efficient cross-cutting of solid wood. Generally in the high range of teeth per inch. **Fig 9.26.**

### Faced Panel Blade

A hollow faced tooth alternates with an inverted 'V' tooth to provide a much cleaner cut in laminated chip boards than is normally possible without the use of a pre-scoring blade. Ideal if your machine has no scoring option. **Fig 9.27.**

### Blade maintenance

It is essential that the blade is in good condition. Any build up of timber resin near the teeth of the blade may cause the work piece to stall or stick. These deposits should be removed with white spirit. After cleaning it is also advisable to coat the blade with silicone spray. Do not use any product which contains oil on the blade as this will attract dirt. Never try to clean a moving blade. The saw should be stopped, the blade removed and the resin removed with a suitable scraper.

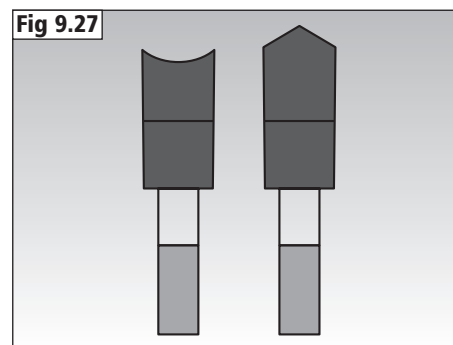
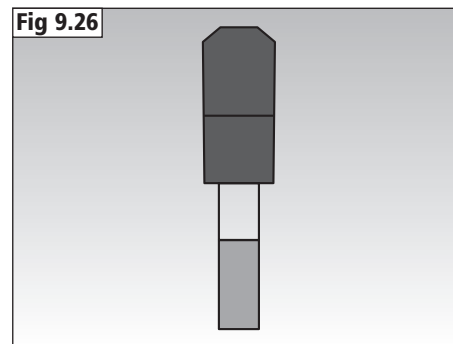
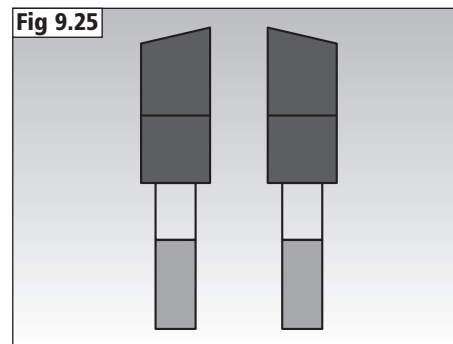
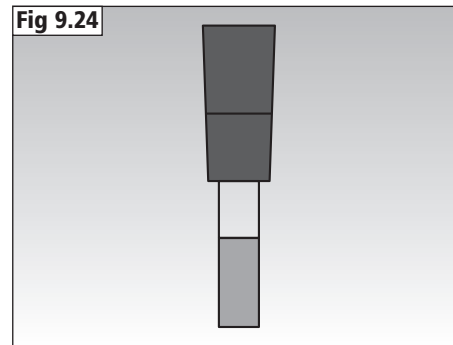

# 9. Operation

## Blade Hook

The angle of the blade tooth profile is referred to as the hook. To identify the hook of a blade, a line can be held from the centre of the blade to the tip of one of its teeth. If the blade profile follows the line, it is a neutral hook blade, **Fig 9.28**. If the blade profile is as shown in **Fig 9.29**, with the top edge of the blade tip facing forward, it is a positive hook. If the blade profile is as shown in **Fig 9.30**, with the top edge of the blade tip further back than the lower part, it is a negative hook.

Neutral hook blades as shown in **Fig 9.28** are designed for use in chop saws, radial arm saws and mitre saws, where the cut will be made from above the work piece. Neutral hook blades should not be used in table saws.

Positive hook blades as shown in **Fig 9.29** are suitable for use in table saws for cutting soft and hard wood. They should not be used to cut laminated material or plywood as the teeth will leave a poor finish to the material.

Negative hook blades as shown in **Fig 9.30** are suitable for use in table saws to cut laminated materials and plywood. This type of blade is designed to minimise splintering of the material's surface around the cut. These blades are ineffective at cutting soft or hard woods and should not be used for this purpose.

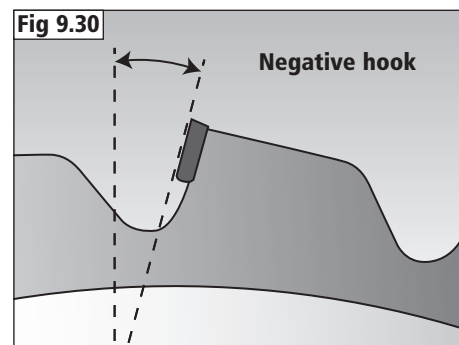
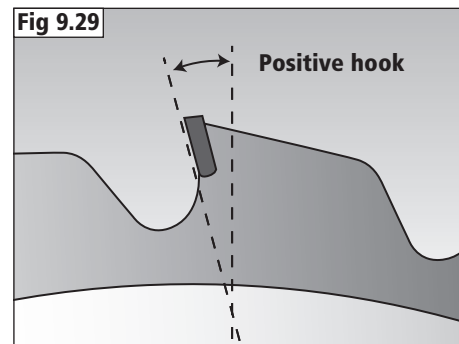
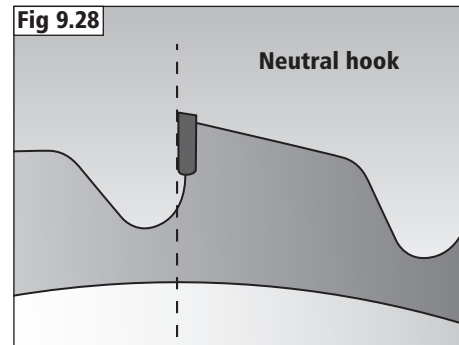

# 10. Dust Extraction

## The Importance of Dust Extraction

Suitable dust extraction is essential to avoid the possibility of serious health problems related to wood dust. It is also necessary in order to ensure the waste producing machine performs safely and effectively. Some woods are extremely toxic and in addition to suitable dust extraction machines it is recommended that PPE such as respirators are also used.

## Record Power Dust Extraction Machines

Below is a summary of the Record Power range. Please visit your local stockist or go online for full details.

### DX1000 Fine Filter 45 Litre Extractor

45 litre capacity, 1 kW motor, 0.5 micron filtration. Includes hose.

### RSDE1 Fine Filter 45 Litre Extractor

45 litre capacity, 1 kW motor, 0.5 micron filtration. Includes hose.

### RSDE/2 Fine Filter 50 Litre Extractor with Accessories

50 litre capacity, 1 kW motor, 0.5 micron filtration, includes wheel kit, hose cuff power tool adaptor hose and spare filter bags. Includes hose.

### RSDE/2A Fine Filter Auto-Switching 50 Litre Extractor with Accessories

50 litre capacity, 1 kW motor, 0.5 micron filtration, includes wheel kit, hose cuff power tool adaptor hose and spare filter bags. Includes hose.

### DX4000 Fine Filter Twin Motor 80 Litre Extractor

80 litre capacity, 2 x 1 kW motors, 0.5 micron filtration. Includes hose.

### DX5000 Fine Filter Twin Motor 200 Litre Extractor

200 litre capacity, 2 x 1 kW motors, 0.5 micron filtration. Includes hose.

### CGV286 CamVac Series Compact Extractor

36 litre capacity, 1 kW motor single or twin, 0.5 micron filtration.

### CGV286-WALL CamVac Series Wall Mounted Extractor

150 litre capacity, 1 kW motor single or twin, 0.5 micron filtration.

### CGV336 CamVac Series Medium Extractor

55 litre capacity, 1 kW motor single or twin, 0.5 micron filtration.

### CGV386 CamVac Series Large Extractor

90 litre capacity, 1 kW motor twin or triple, 0.5 micron filtration.

### CGV486 CamVac Series Heavy Duty Extractor

200 litre capacity, 1 kW triple motor, 0.5 micron filtration.

### CX2000 Compact Chip Collector

54 litre capacity, 0.56 kW motor. Includes hose.

### CX2500 80 Litre Chip Collector

80 litre capacity, 0.55 kW motor. Includes hose.

### CX3000 Heavy Duty Chip Collector

128 litre capacity, 0.56 kW motor. Includes hose.













































































### AC400 2 Stage Air filter with Remote, 3 speeds and Time Delay

Collects airborne dust, 1 micron filtration.

 Recommended for heavy use

 Recommended for light / intermittent use

 Can be used

	Bandsaws	Table Saws	Planer Thicknessers	Lathes	Sanding Machines	Dust Extraction Systems	Airborne Dust Collection
DX1000							
RSDE1							
RSDE/2							
RSDE/2A							
DX4000							
DX5000							
CGV286							
CGV286-WALL							
CGV336							
CGV386							
CGV486							
CX2000							
CX2500							
CX3000							
AC400							

# 11. Maintenance



**Warning: Disconnect the power supply before carrying out maintenance.**

**Only correctly sharpened saw blades manufactured in accordance with the requirements of EN 847-1:2005 should be used. Do not use a saw blade that has a maximum marked speed which is lower than the maximum speed of the TS2 saw blade.**



**Before replacing the main blade, ensure that the squaring frame is removed.**

## Replacing the Main Blade

To remove the main blade, first fully extend the sliding carriage to gain access to the main blade. Next, release the yellow blade guard to de-activate the microswitch to ensure that the machine will not start during the blade removal process, **Fig 11.1**.

Then, line-up the the blade collar hole with the table insert hole. To do so, rotate the blade to ensure that the blade collar hole is facing towards the top of the blade. To check that the blade collar hole is facing in the correct direction, look through the table insert hole. Next, insert a tommy bar as shown in **Fig 11.2**. This will secure the main blade in a fixed position for removal. Once the blade is secure in a fixed position, loosen the blade nut using the supplied 41 mm wrench, **Fig 11.3**.

**NOTE: The main blade nut is a left hand thread to prevent it from loosening during use.**

## Replacing the Scoring Blade

To remove the scoring blade, first secure the scoring blade shaft in a fixed position with use of the 13 mm wrench and loosen the scoring blade nut with use of the 27 mm wrench, as shown in **Fig 11.4**.



**Ensure that the main blade and scoring blade are fully lowered to gain required access when replacing the drive belt.**

## Replacing the Main Blade Drive Belts

To gain the required access to the main blade drive belts for removal, remove the main table by removing the lower M10 nuts with using a 18 mm wrench, followed by the large washer and spring washer and do so at all 4 corners of the table, as shown in **Fig 11.5**.

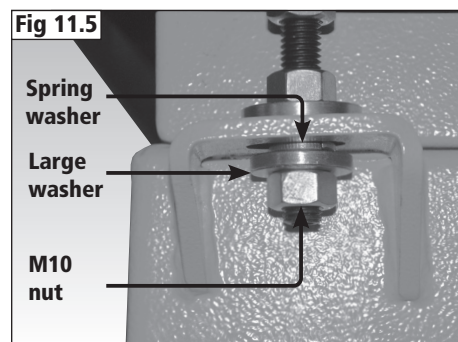
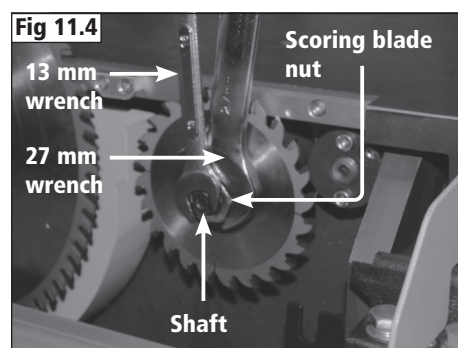
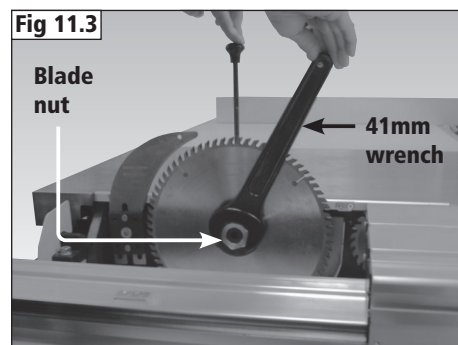
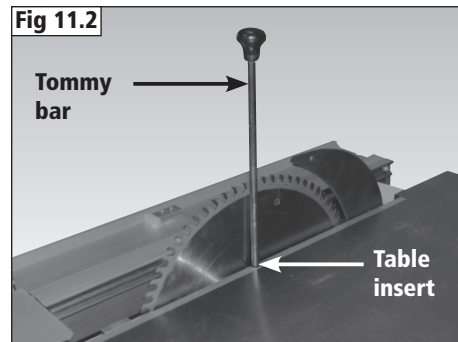
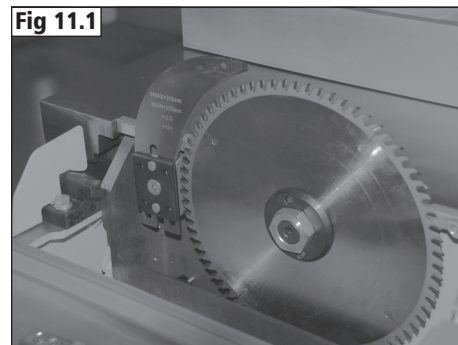

# 11. Maintenance



Once the main table has been removed, release the screw rod nut using a 10 mm hex wrench, **Fig 11.6**. Then, raise and pivot the motor to release the tension on the 2 drive belts, as shown in **Fig 11.7**. Once the tension is released, remove the 2 drive belts and replace.

## Replacing the Scoring Blade Drive Belt

Similar to the main blade drive belts, to replace the scoring blade drive belt, raise and pivot the motor to dis-engage the hydraulic arm to release the tension, **Fig 11.8**. Once the tension is released, remove the drive belt and replace.

## General Cleaning

Periodically clean the machine and all of its parts, vacuum the shavings and dust and remove any resin residues.

In particular, clean the following parts:

The sliding carriage 'T' slots, **Fig 11.9**.

The squaring frame extendable arm, **Fig 11.10**.

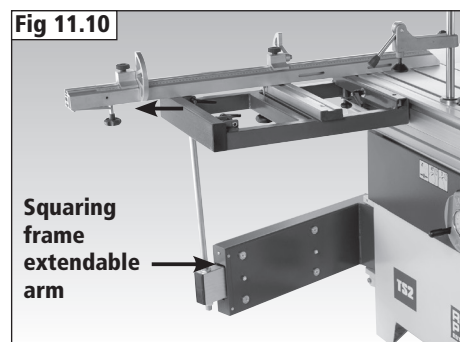
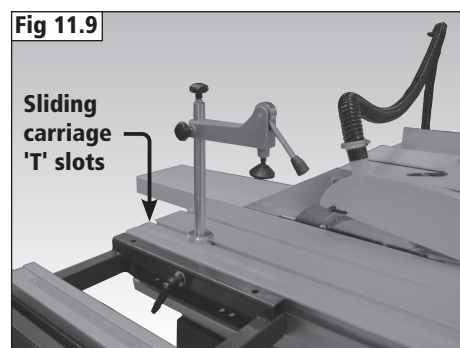
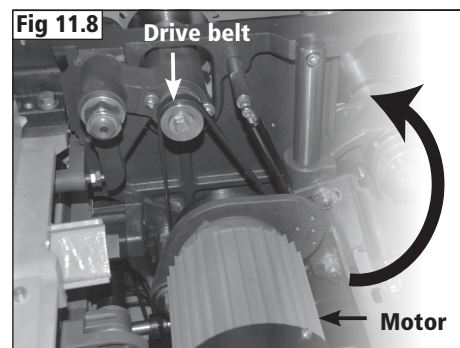
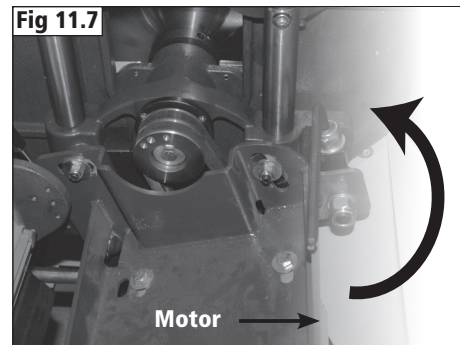
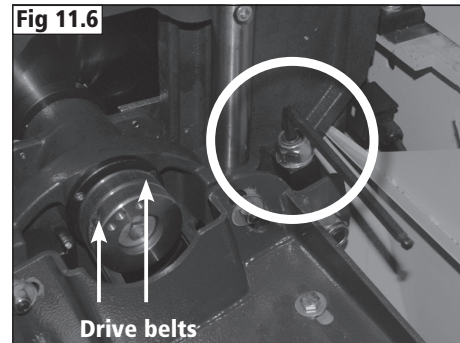

# 11. Maintenance



## General Lubrication

Weekly clean and lubricate all the mobile couplings of the machine, as shown in **Fig 11.11**, with use of a thin film of oil and grease.

Protect all belts and pulleys to avoid contamination with oil.

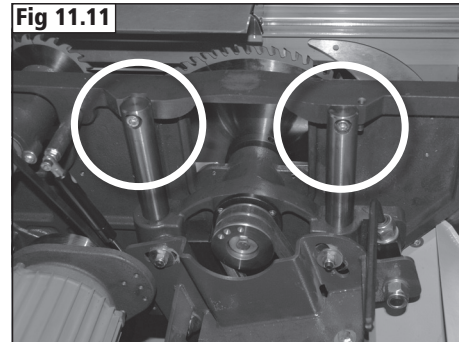

# 12. Troubleshooting



For any information or problem contact your area dealer or our technical service centre. The necessary interventions must be carried out by specialised technical personnel.

Before carrying out any fault service or maintenance work, please always TURN OFF THE SWITCH, UNPLUG POWER CABLE AND WAIT FOR THE SAW BLADE TO COME TO A STANDSTILL.

Problem	Possible Cause	Solution
Saw stops or will not start	<ol style="list-style-type: none"> <li>1. Overload tripped on motor</li> <li>2. Machine unplugged</li> <li>3. Fuse blown or circuit breaker tripped</li> <li>4. Cord damaged</li> <li>5. Microswitch contact not made</li> </ol>	<ol style="list-style-type: none"> <li>1. Allow motor to cool before restarting machine</li> <li>2. Connect the machine to the electricity supply</li> <li>3. Replace fuse or reset circuit breaker</li> <li>4. Replace power cord</li> <li>5. Ensure contact is made</li> </ol>
Does not make accurate 45° or 90° cuts	<ol style="list-style-type: none"> <li>1. Stops not adjusted correctly</li> <li>2. Angle pointer not set accurately</li> </ol>	<ol style="list-style-type: none"> <li>1. Check blade with square and adjust stops</li> <li>2. Check blade with square and adjust pointer</li> </ol>
Material binds blade when ripping	<ol style="list-style-type: none"> <li>1. Fence not aligned with blade</li> <li>2. Warped wood</li> <li>3. Excessive feed rate</li> <li>4. Riving knife not aligned with blade</li> </ol>	<ol style="list-style-type: none"> <li>1. Check and adjust fence</li> <li>2. Select another piece of wood</li> <li>3. Reduce feed rate</li> <li>4. Align Riving knife with blade</li> </ol>
Saw makes unsatisfactory cuts	<ol style="list-style-type: none"> <li>1. Dull blade</li> <li>2. Blade mounted backwards</li> <li>3. Gum or pitch on blade</li> <li>4. Incorrect blade for cut</li> <li>5. Gum or pitch on table</li> </ol>	<ol style="list-style-type: none"> <li>1. Sharpen or replace blade</li> <li>2. Turn blade around</li> <li>3. Remove blade and clean</li> <li>4. Change blade to correct type</li> <li>5. Clean table</li> </ol>
Blade does not come up to speed	<ol style="list-style-type: none"> <li>1. Extension cord too light or long</li> <li>2. Low voltage</li> <li>3. Motor not wired for correct voltage</li> </ol>	<ol style="list-style-type: none"> <li>1. Replace with adequate size cord</li> <li>2. Contact your local electrical company / have supply and circuit checked.</li> <li>3. Refer to motor specification plate</li> </ol>
Saw vibrates excessively	<ol style="list-style-type: none"> <li>1. Stood on uneven floor</li> <li>2. Damaged saw blade</li> <li>3. Worn V-belts</li> <li>4. Pulleys out of true</li> <li>5. Improper motor mounting</li> <li>6. Excessive play in raising mechanism</li> <li>7. Loose fixings</li> </ol>	<ol style="list-style-type: none"> <li>1. Reposition on flat, level surface</li> <li>2. Replace saw blade</li> <li>3. Replace V-belts</li> <li>4. Replace pulley</li> <li>5. Check and adjust motor</li> <li>6. Adjust worm and arbor bracket</li> <li>7. Tighten hardware</li> </ol>
Rip fence binds on guide rails	<ol style="list-style-type: none"> <li>1. Guide rails or extension table not installed correctly</li> <li>2. Guide rail of rip fence not adjusted properly</li> </ol>	<ol style="list-style-type: none"> <li>1. Reassemble extension, as described in this manual</li> <li>2. Adjust guide rail, as described in this manual</li> </ol>
Blade does not raise or tilt freely	<ol style="list-style-type: none"> <li>1. Too much tension in raising mechanism</li> <li>2. Sawdust and debris in raising and tilting mechanisms</li> </ol>	<ol style="list-style-type: none"> <li>1. Adjust raising worm screw and arbor bracket</li> <li>2. Clean and regrease</li> </ol>
Material kicks back from blade	<ol style="list-style-type: none"> <li>1. Rip fence out of alignment</li> <li>2. Riving knife not aligned with blade</li> <li>3. Feeding stock without rip fence</li> <li>4. Riving knife not in place</li> <li>5. Dull blade</li> <li>6. Letting go of material before it has fully passed the blade</li> <li>7. Anti kick-back plates are dull</li> </ol>	<ol style="list-style-type: none"> <li>1. Align the rip fence with the mitre slot</li> <li>2. Align the riving knife with the blade</li> <li>3. Install and use the rip fence</li> <li>4. Install and use the riving knife (with guard)</li> <li>5. Replace the blade</li> <li>6. Push the material fully past the blade before releasing</li> <li>7. Replace or sharpen the anti kick-back plates</li> </ol>

# 13. Electrical Connection and Wiring Diagram

Machines supplied for use in the UK are fitted with a 3 pin plug conforming to BS1363, fitted with a fuse conforming to BS1362 and appropriate to the current rating of the machine.

Machines supplied for use in other countries within the European Union are fitted with a 2 pin Schuko plug conforming to CEE 7/7.

Machines supplied for use in Australia and New Zealand are fitted with a 3 pin plug conforming to AS/NZS3112.

In all cases, if the original plug or connector has to be replaced for any reason, the wires within the mains power cable are colour coded as follows:

## 230 V (Single Phase)

- Brown: Live (L)
- Blue: Neutral (N)
- Green and Yellow: Earth (E)

The wire coloured brown must always be connected to the terminal marked 'L' or coloured red.

The wire coloured blue must always be connected to the terminal marked 'N' or coloured black.

The wire coloured green and yellow must always be connected to the terminal marked 'E' or with the earth symbol:



or coloured green / green and yellow.

It is important that the machine is effectively earthed. Some machines will be clearly marked with the double insulated logo:



In this case there will not be an earth wire within the circuit.

In the case of the BS1363 plug for use in the UK, always ensure that it is fitted with a fuse conforming to BS1362 appropriate to the rating of the

machine. If replacing the original fuse, always fit a fuse of equivalent rating to the original. Never fit a fuse of a higher rating than the original. Never modify the fuse or fuse holder to accept fuses of a different type or size.

Where the current rating of the machine exceeds 13 A at 230 V, or if the machine is designated for use on a 400 V 3 phase supply a connector conforming to BS4343 (CEE17 / IEC60309) will be used.

230 V machines will be fitted with a blue 3 pin connector. The wiring for this type of this connector will be the same as shown above.

400 V, 3 phase machines will be fitted with a red 4 or 5 pin connector. The wiring for this type of connector is as shown below:

## 400 V (3 phase)

- Brown: Live (L1)
- Black: Live (L2)
- Grey: Live (L3)
- Blue: Neutral (N)
- Green and Yellow: Earth (E)

The wire coloured brown must always be connected to the terminal marked 'L1'.

The wire coloured black must always be fitted to the terminal marked 'L2'.

The wire coloured grey must always be connected to the terminal marked 'L3'.

The wire coloured blue must always be connected to the terminal marked 'N' or coloured black.

The wire coloured green and yellow must always be connected to the terminal marked 'E' or with the earth symbol

If in doubt about the connection of the electrical supply, always consult a qualified electrician.

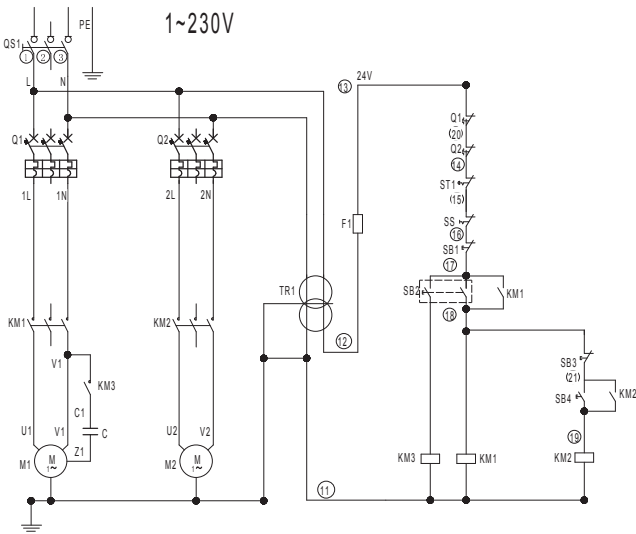

TS2/UK1

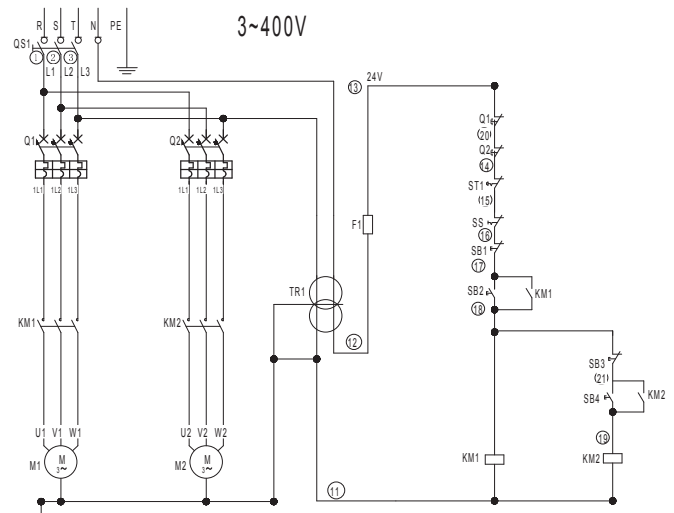

TS2/UK3



# 14. Parts Lists and Diagrams

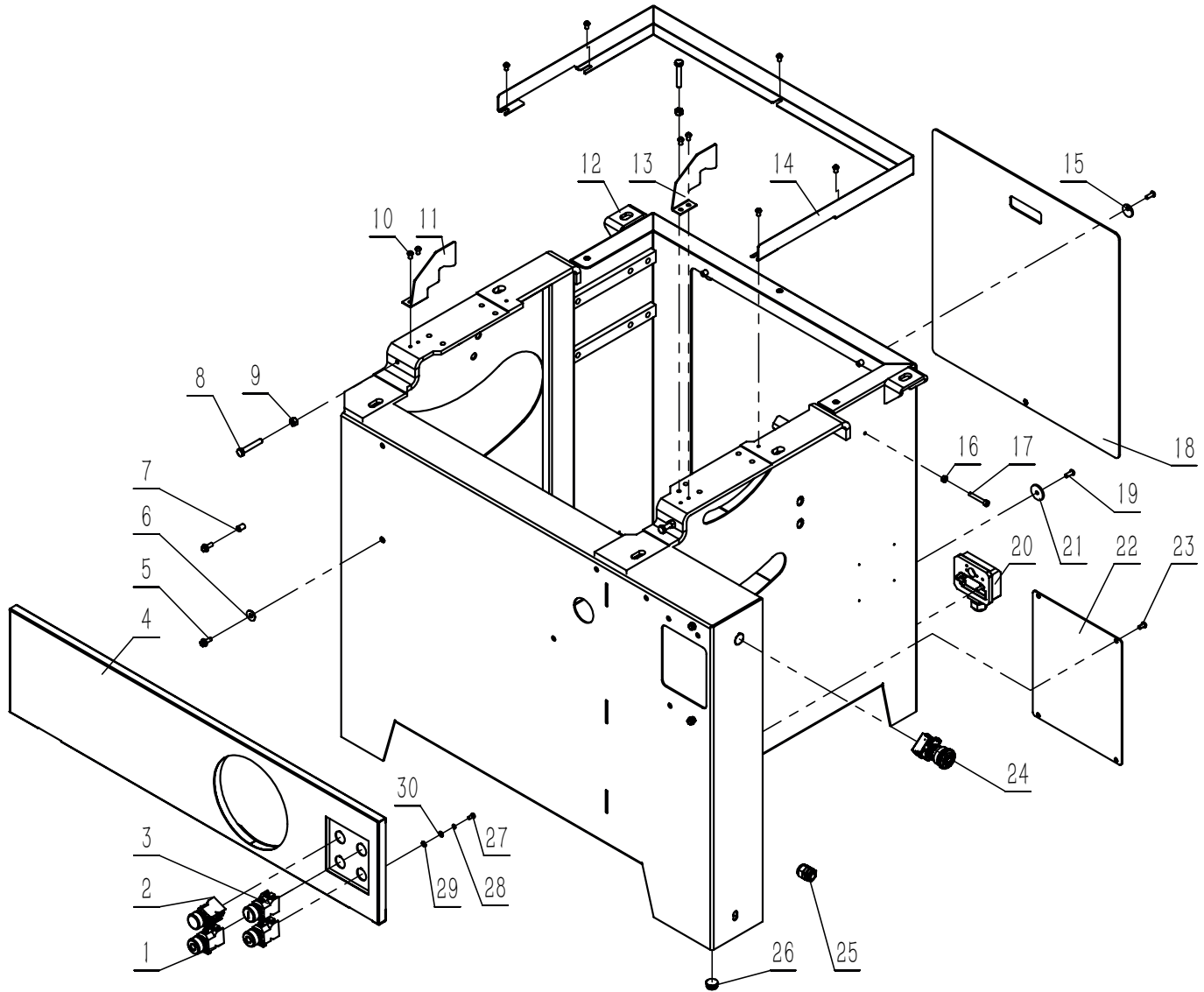

Item	Description	Part Number	Quantity	Item	Description	Part Number	Quantity
1-1	Stop button	45101	2	1-17	Hexagon socket screw	46113	1
1-2	Start button	45102	1	1-18	Rear panel	46114	1
1-3	Start button	45102	1	1-19	Hex socket button head screw	46115	4
1-4	Front panel assembly	46100	1	1-20	Wiring box assembly (230V)	46116	1
1-5	Bolt	46101	4	1-21	Wiring box assembly (400V)	46117	1
1-6	Spacer	46102	2	1-22	Spacer	46118	2
1-7	Nut	46103	11	1-23	Electrical box panel	46119	1
1-8	Hex bolt	46104	3	1-24	Hex socket screw	46120	4
1-9	Hex nut	46105	3	1-25	Emergency stop button	46121	1
1-10	Hex socket screw	46106	9	1-26	Cable gland	46122	2
1-11	Guard plate	46107	1	1-27	End cap	46123	1
1-12	Frame	46108	1	1-28	Cross recess pan head screw	46124	2
1-13	Guard plate	46109	1	1-29	Spring washer	46125	2
1-14	Frame guard	46110	1	1-30	Washer	46126	2
1-15	Washer	46111	2		Washer	46127	2
1-16	Hex nut	46112	1				

# 14. Parts Lists and Diagrams

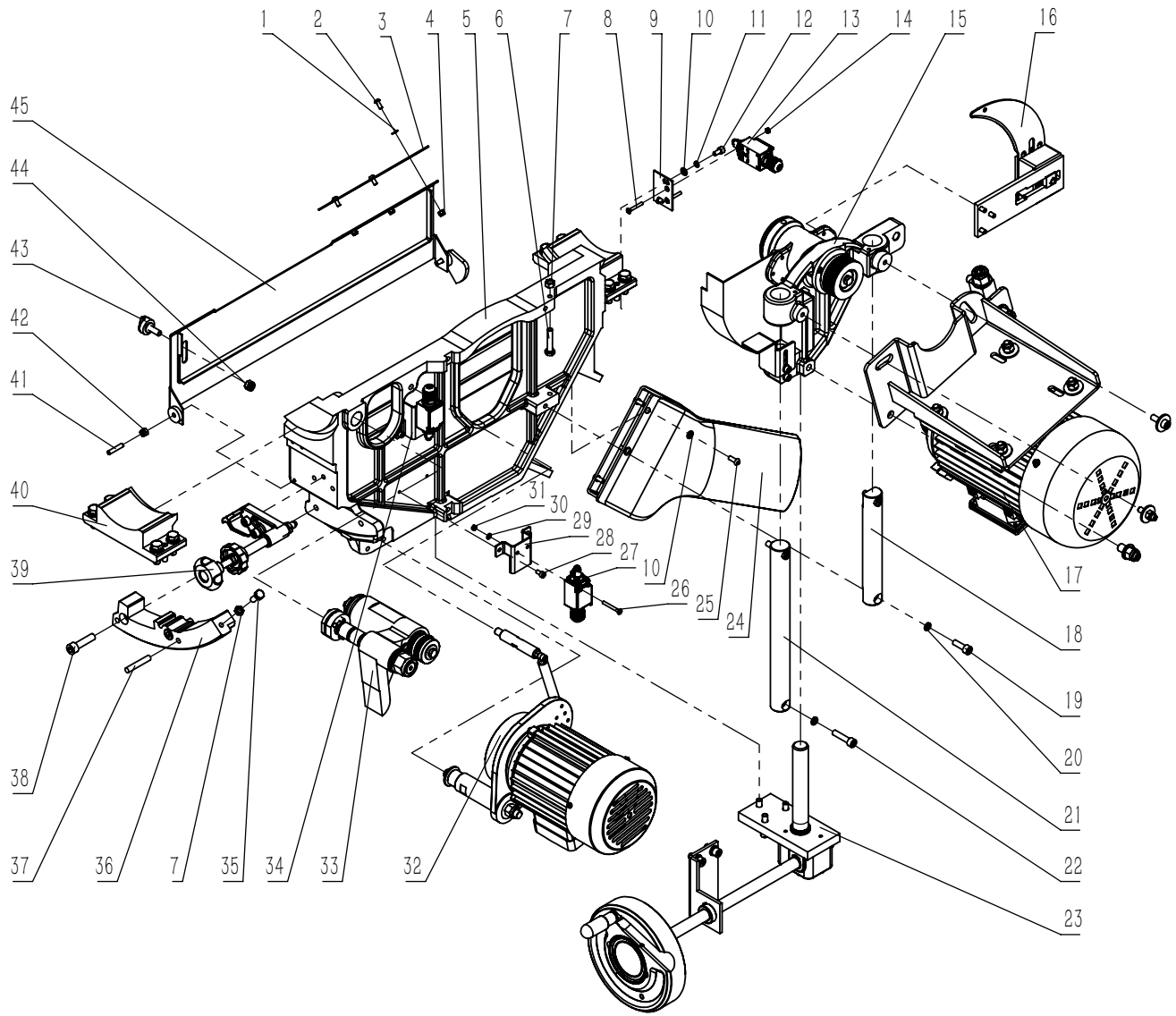

Item	Description	Part Number	Quantity	Item	Description	Part Number	Quantity
2-1	Washer	46128	3	2-24	Dust port	46151	1
2-2	Screw	46129	3	2-25	Screw	46152	4
2-3	Plate	46130	1	2-26	Screw	46153	4
2-4	Locking nut	46131	3	2-27	Micro switch	46154	2
2-5	Bracket	46132	1	2-28	Screw	46155	4
2-6	Bolt	46133	1	2-29	Micro switch seat	46156	1
2-7	Nut	46134	2	2-30	Washer	46157	4
2-8	Screw	46135	2	2-31	Nut	46158	4
2-9	Switch seat plate	46136	1	2-32	Scoring motor assembly	46159	1
2-10	Washer	46137	6	2-33	Scoring shaft seat assembly	46160	1
2-11	Spring washer	46138	2	2-34	Micro switch seat	46161	1
2-12	Screw	46139	2	2-35	Bolt	46162	2
2-13	Micro switch	46140	1	2-36	Worm gear	46163	1
2-14	Nut	46141	2	2-37	Pin	46164	2
2-15	Shaft seat assembly	46142	1	2-38	Screw	46165	2
2-16	Riving knife assembly	46143	1	2-39	Locking handle	46166	1
2-17	Main motor assembly	46144	1	2-40	Rotating support bracket	46167	1
2-18	Guide rail	46145	1	2-41	Screw	46168	2
2-19	Nut	46146	2	2-42	Locking nut	46169	2
2-20	Spring washer	46147	4	2-43	Locking handle	46170	1
2-21	Guide rail	46148	1	2-44	Locking nut	46171	2
2-22	Nut	46149	2	2-45	Blade guard	46172	1
2-23	Lifting screw assembly	46150	1				

# 14. Parts Lists and Diagrams

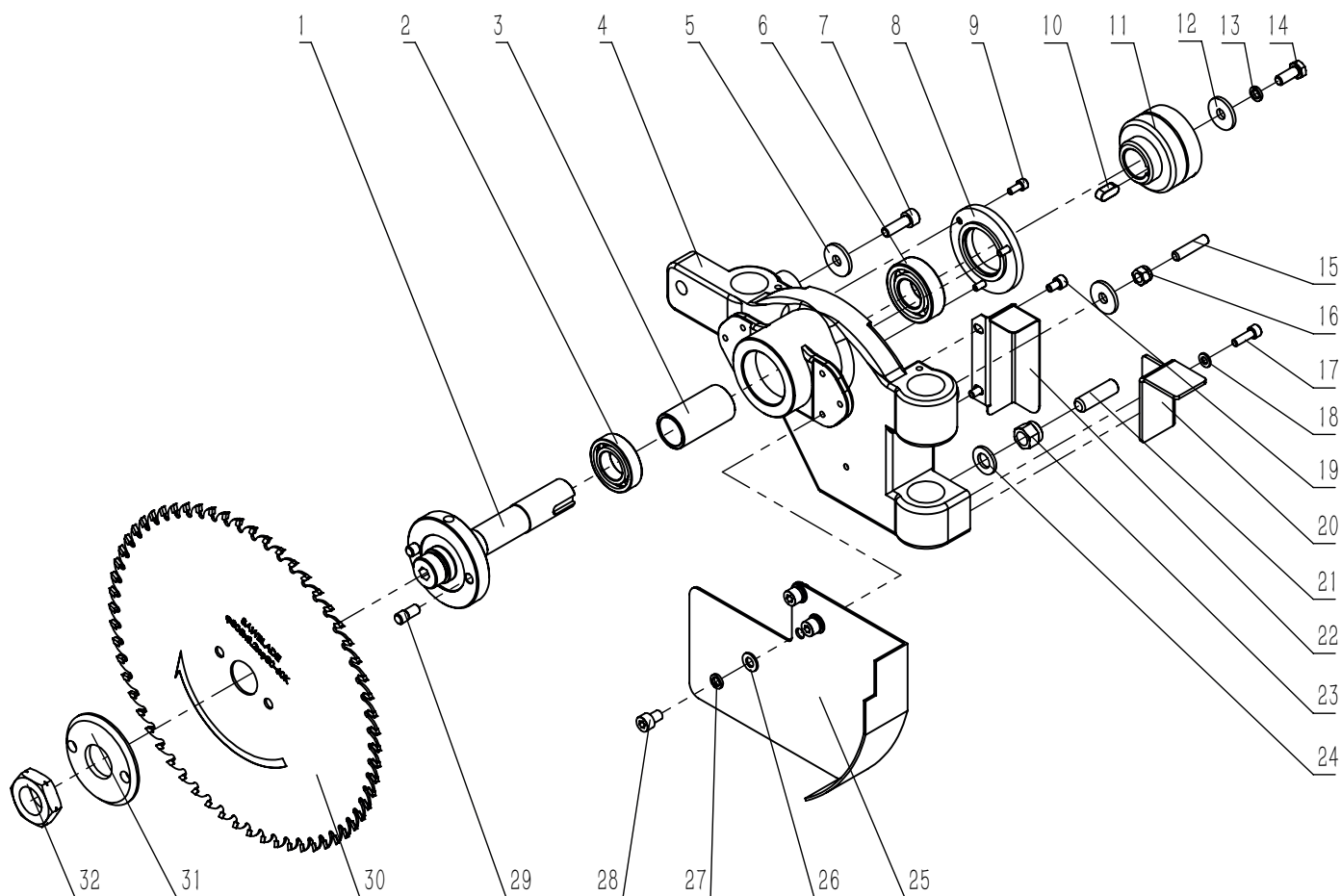

Item	Description	Part Number	Quantity	Item	Description	Part Number	Quantity
3-1	Spindle shaft	46173	1	3-17	Screw	46189	2
3-2	Bearing	46174	1	3-18	Washer	46190	2
3-3	Sleeve	46175	1	3-19	Screw	46191	2
3-4	Spindle seat	46176	1	3-20	Plate	46192	1
3-5	Washer	46177	2	3-21	Screw	46193	1
3-6	Screw	46178	1	3-22	Lead screw dust cover	46194	1
3-7	Bearing	46179	1	3-23	Locking nut	46195	1
3-8	Bearing end cap	46180	1	3-24	Washer	46196	1
3-9	Screw	46181	3	3-25	Guide plate	46197	1
3-10	Flat key	46182	1	3-26	Washer	46198	3
3-11	Spindle pulley	46183	1	3-27	Spring washer	46199	3
3-12	Washer	46184	1	3-28	Screw	46200	3
3-13	Spring washer	46185	1	3-29	Position pin	46201	2
3-14	Screw	46186	1	3-30	Main blade	46202	1
3-15	Screw	46187	1	3-31	Flange	46203	1
3-16	Locking nut	46188	1	3-32	Locking nut	46204	1

# 14. Parts Lists and Diagrams

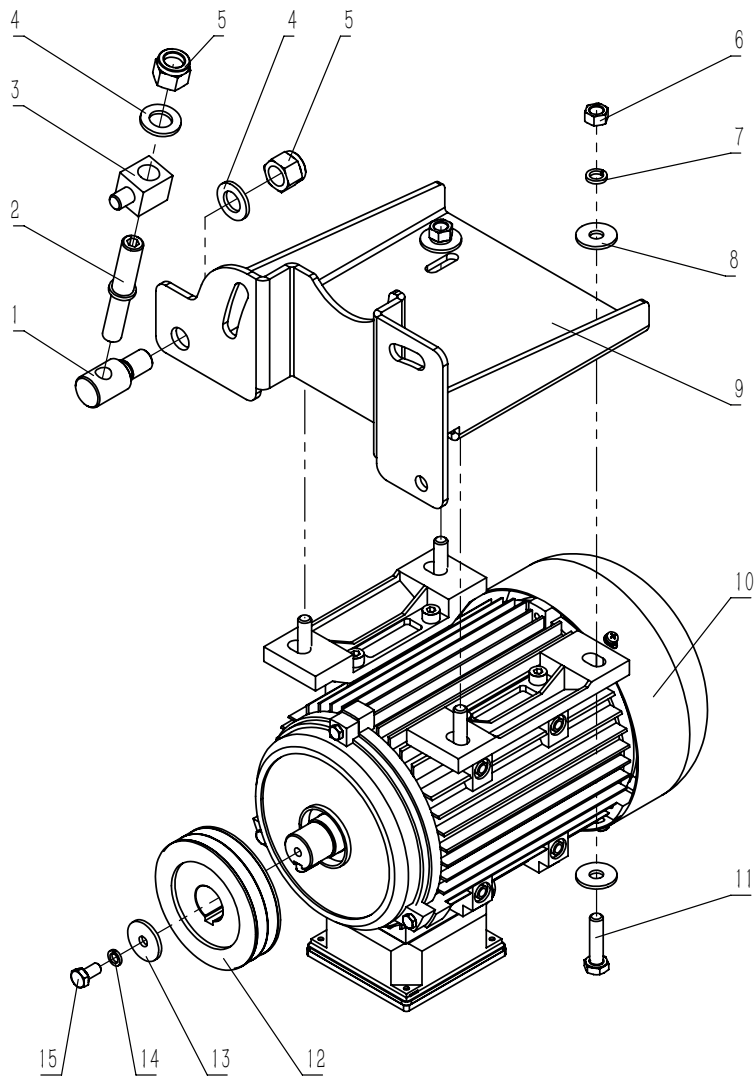

Item	Description	Part Number	Quantity	Item	Description	Part Number	Quantity
4-1	Adjustment nut	46205	1	4-10	Motor (230V)	45119	1
4-2	Threaded rod	46206	1		Motor (400V)	45120	1
4-3	Tension block	46207	1	4-11	Bolt	46214	4
4-4	Flat washer	46208	2	4-12	Motor pulley (230V)	45121	1
4-5	Screw	46209	2		Motor pulley (400V)	46215	1
4-6	Screw	46210	4	4-13	Washer	46216	1
4-7	Spring washer	46211	4	4-14	Spring washer	46217	1
4-8	Big washer	46212	8	4-15	Screw	46218	1
4-9	Motor seat	46213	1				

# 14. Parts Lists and Diagrams

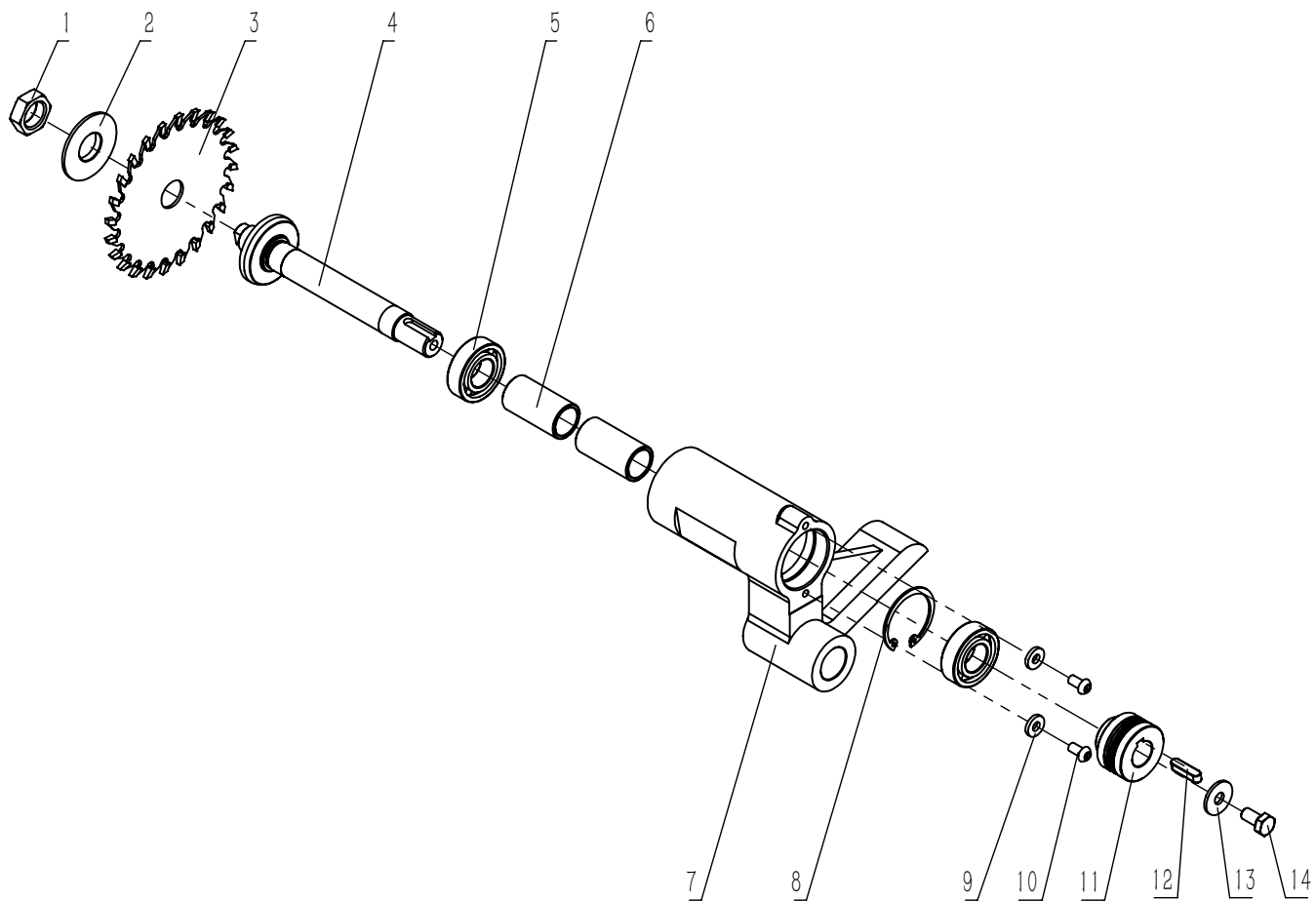

Item	Description	Part Number	Quantity
5-1	Screw	46219	1
5-2	Scoring blade flange	46220	1
5-3	Blade	46221	1
5-4	Spindle	46222	1
5-5	Bearing	46223	2
5-6	Sleeve	46224	2
5-7	Scoring spindle seat	46225	1
5-8	Circlip	46226	1
5-9	Spacer	46227	2
5-10	Screw	46228	2
5-11	Scoring spindle pulley	46229	1
5-12	Flat key	46230	1
5-13	Big washer	46231	1
5-14	Screw	46232	1

# 14. Parts Lists and Diagrams

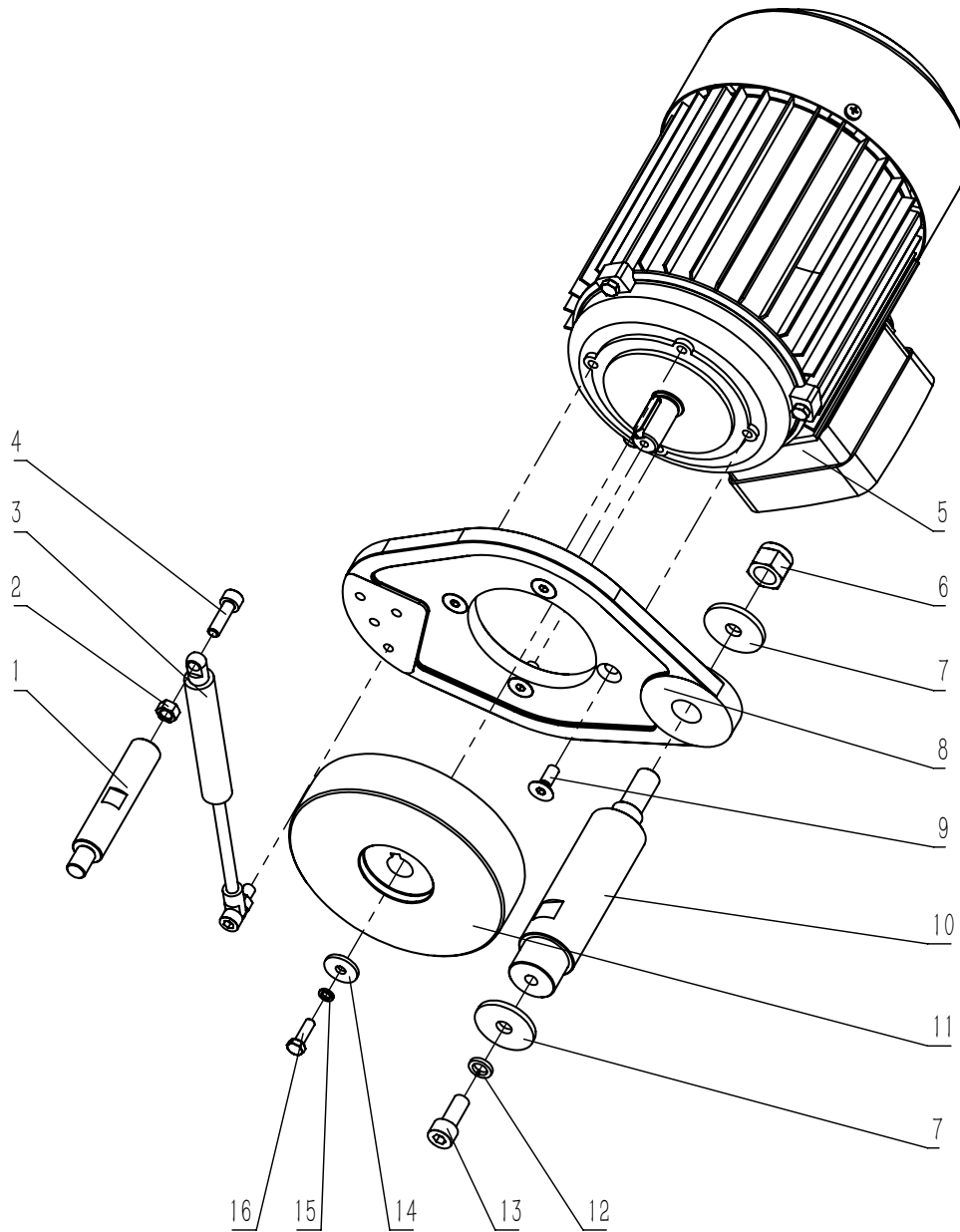

Item	Description	Part Number	Quantity	Item	Description	Part Number	Quantity
6-1	Support shaft	46233	1	6-9	Screw	46240	4
6-2	Nut	46234	2	6-10	Support shaft	46241	1
6-3	Gas springs	46235	1	6-11	Scoring motor pulley	46242	1
6-4	Nut	46236	2	6-12	Spring washer	46243	1
6-5	Motor (230V)	45154	1	6-13	Screw	46244	1
	Motor (400V)	45155	1	6-14	Big washer	46245	1
6-6	Nut	46237	1	6-15	Spring Washer	46246	1
6-7	Washer	46238	2	6-16	Bolt	46247	1
6-8	Scoring motor plate	46239	1				

# 14. Parts Lists and Diagrams

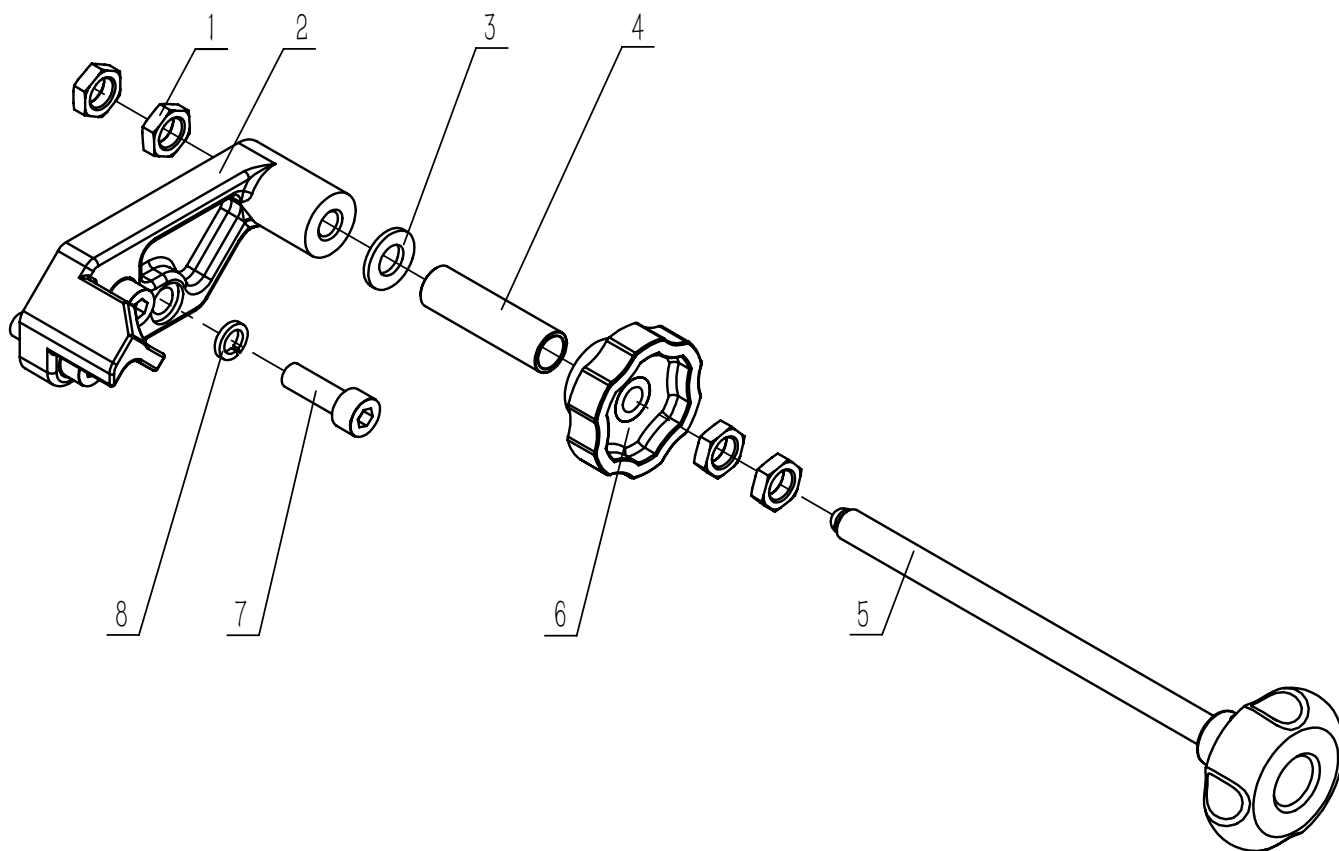

Item	Description	Part Number	Quantity
7-1	Nut	46248	4
7-2	Scoring adjustment seat	46249	1
7-3	Flat washer	46250	1
7-4	Sleeve	46251	1
7-5	Locking handle	46252	1
7-6	Locking wheel	46253	1
7-7	Screw	46254	3
7-8	Spring washer	46255	3

# 14. Parts Lists and Diagrams

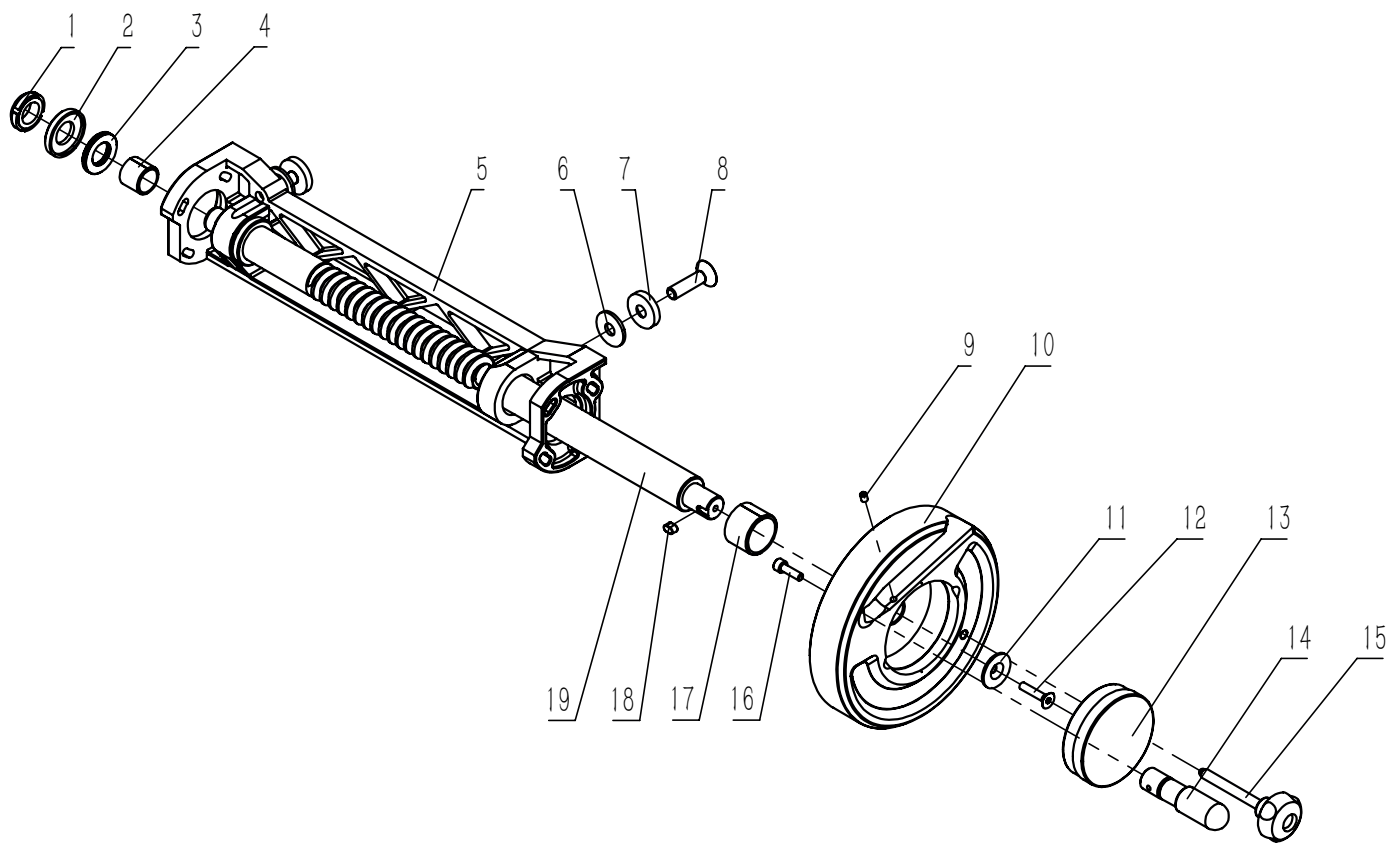

Item	Description	Part Number	Quantity
8-1	Round nut	46256	1
8-2	Aluminium cover	46257	2
8-3	Bearing	46258	2
8-4	Axle sleeve	46259	1
8-5	Shaft seat	46260	1
8-6	Big washer	46261	3
8-7	Spacer	46262	3
8-8	Screw	46263	3
8-9	Screw	46264	1
8-10	Handwheel	46265	1
8-11	Washer	46266	1
8-12	Screw	46267	1
8-13	Tilting indicator	46268	1
8-14	Handle	46269	1
8-15	Round handle	46270	1
8-16	Screw	46271	1
8-17	Axle sleeve	46272	1
8-18	Flat key	46273	1
8-19	Worm	46274	1



# 14. Parts Lists and Diagrams

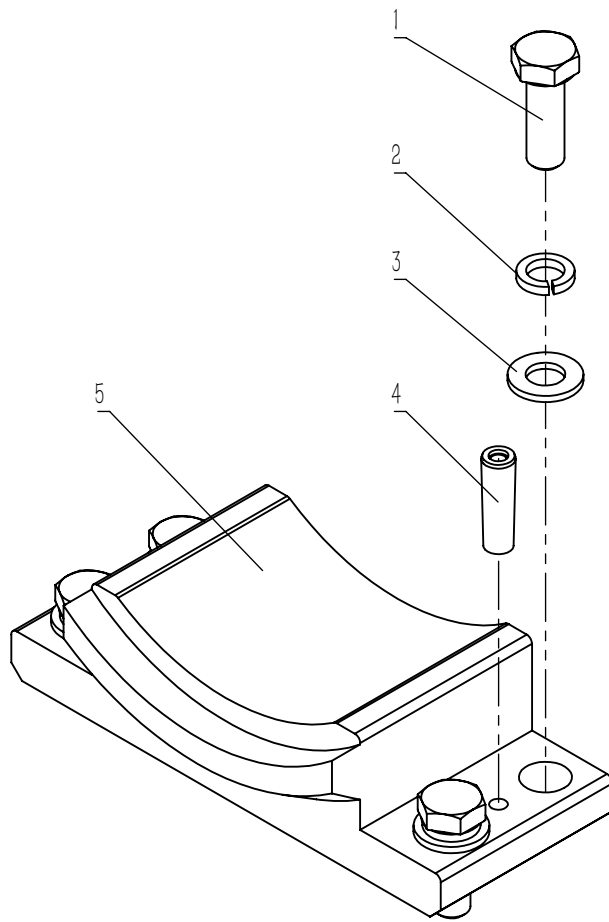

Item	Description	Part Number	Quantity
9-1	Bolt	46275	4
9-2	Spring washer	46276	4
9-3	Washer	46277	4
9-4	Round pin	46278	2
9-5	Rotating support bracket	46279	1

# 14. Parts Lists and Diagrams

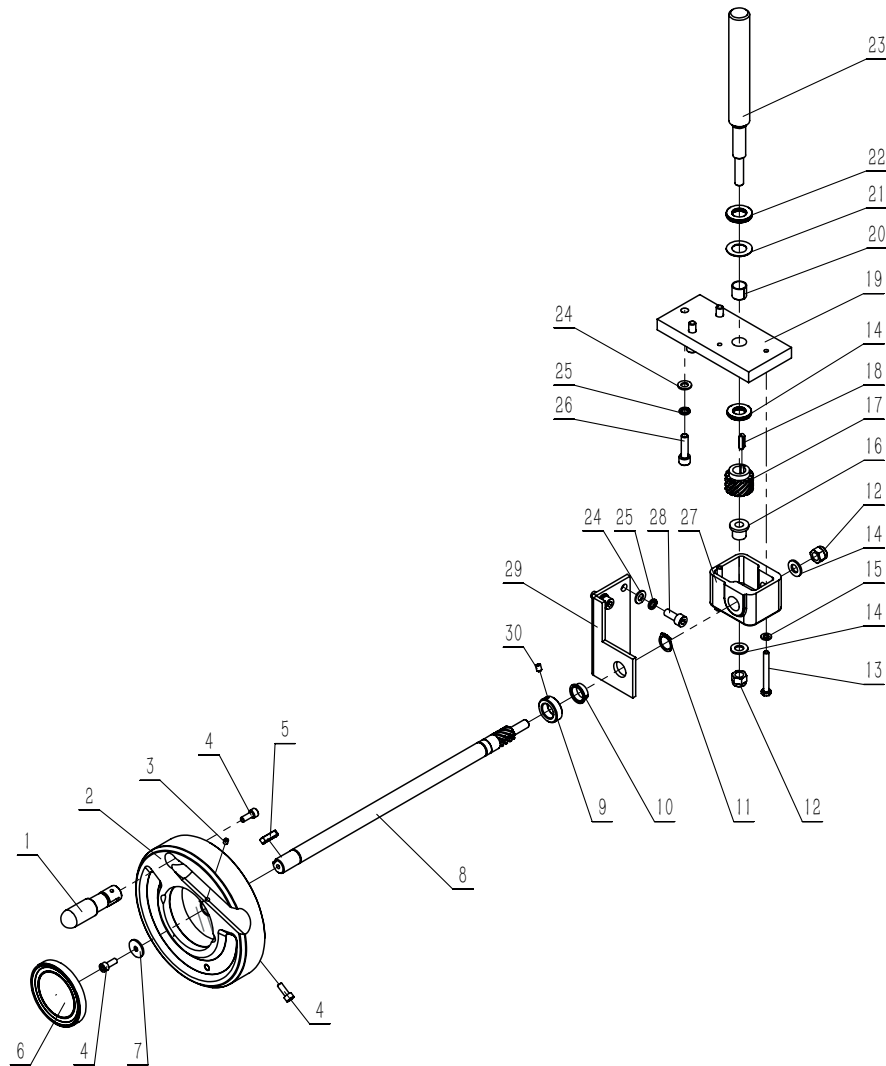

Item	Description	Part Number	Quantity	Item	Description	Part Number	Quantity
10-1	Handle	46280	1	10-16	Shaft sleeve	46295	1
10-2	Handwheel	46281	1	10-17	Gear	46296	1
10-3	Set screw	46282	1	10-18	Flat key	46297	1
10-4	Screw	46283	3	10-19	Bracket	46298	1
10-5	Flat key	46284	1	10-20	Shaft sleeve	46299	1
10-6	Handwheel	46285	1	10-21	Washer	46300	1
10-7	Big washer	46286	1	10-22	Bearing	46301	1
10-8	Gear shaft	46287	1	10-23	Lifting rod	46302	1
10-9	Locking sleeve	46288	1	10-24	Washer	46303	5
10-10	Shaft sleeve	46289	1	10-25	Spring washer	46304	5
10-11	Retaining ring	46290	1	10-26	Screw	46305	3
10-12	Nut	46291	2	10-27	Gear Seat	46306	1
10-13	Bolt	46292	2	10-28	Screw	46307	2
10-14	Bearing	46293	1	10-29	Support plate	46308	1
10-15	Flat washer	46294	2	10-30	Set screw	46309	1

# 14. Parts Lists and Diagrams

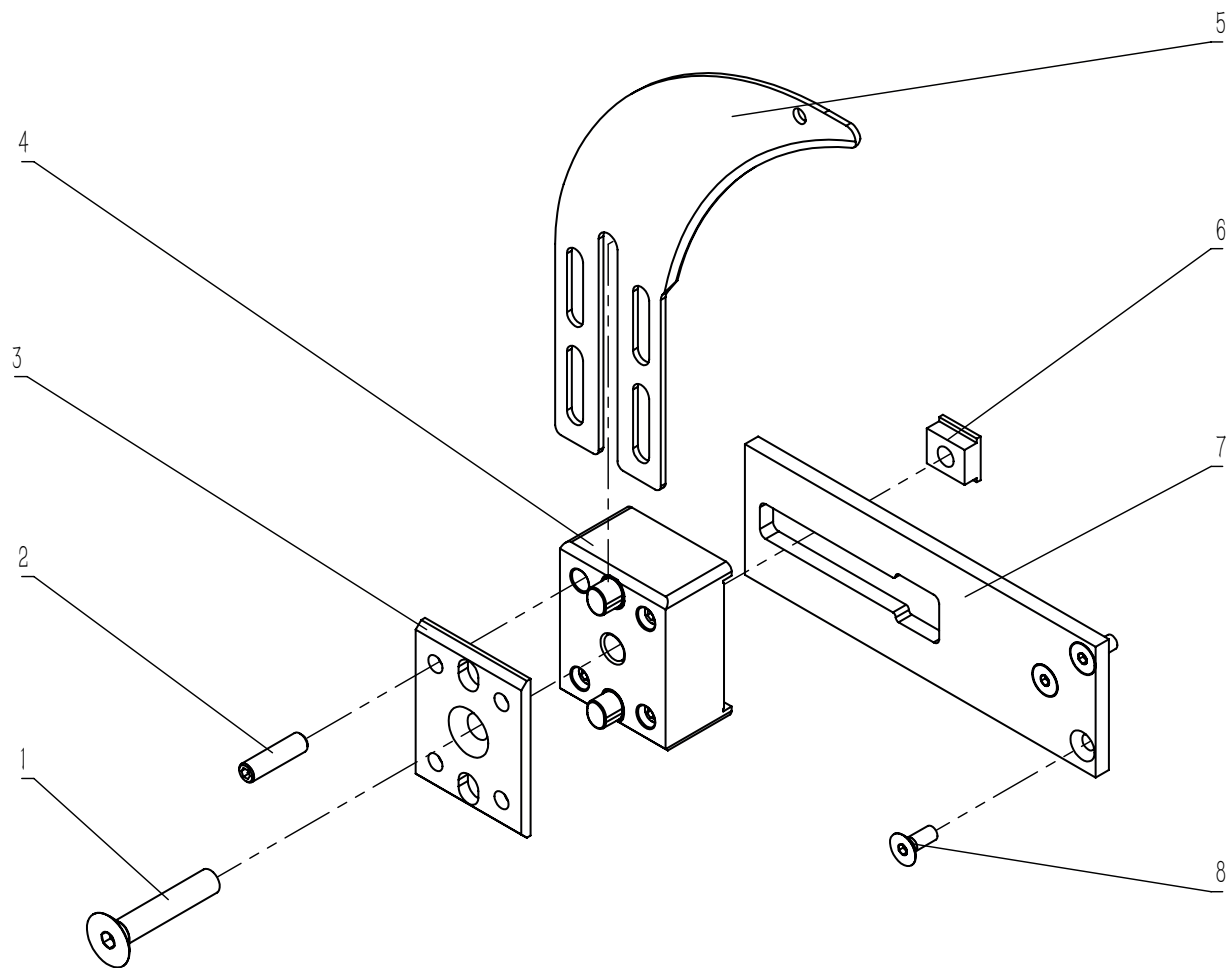

Item	Description	Part Number	Quantity
11-1	Screw	46310	1
11-2	Set screw	46311	4
11-3	Riving knife lock plate	46312	1
11-4	Riving knife adjustment plate	46313	1
11-5	Riving shaft	46314	1
11-6	Locking block	46315	1
11-7	Riving knife seat	46316	1
11-8	Screw	46317	3

# 14. Parts Lists and Diagrams

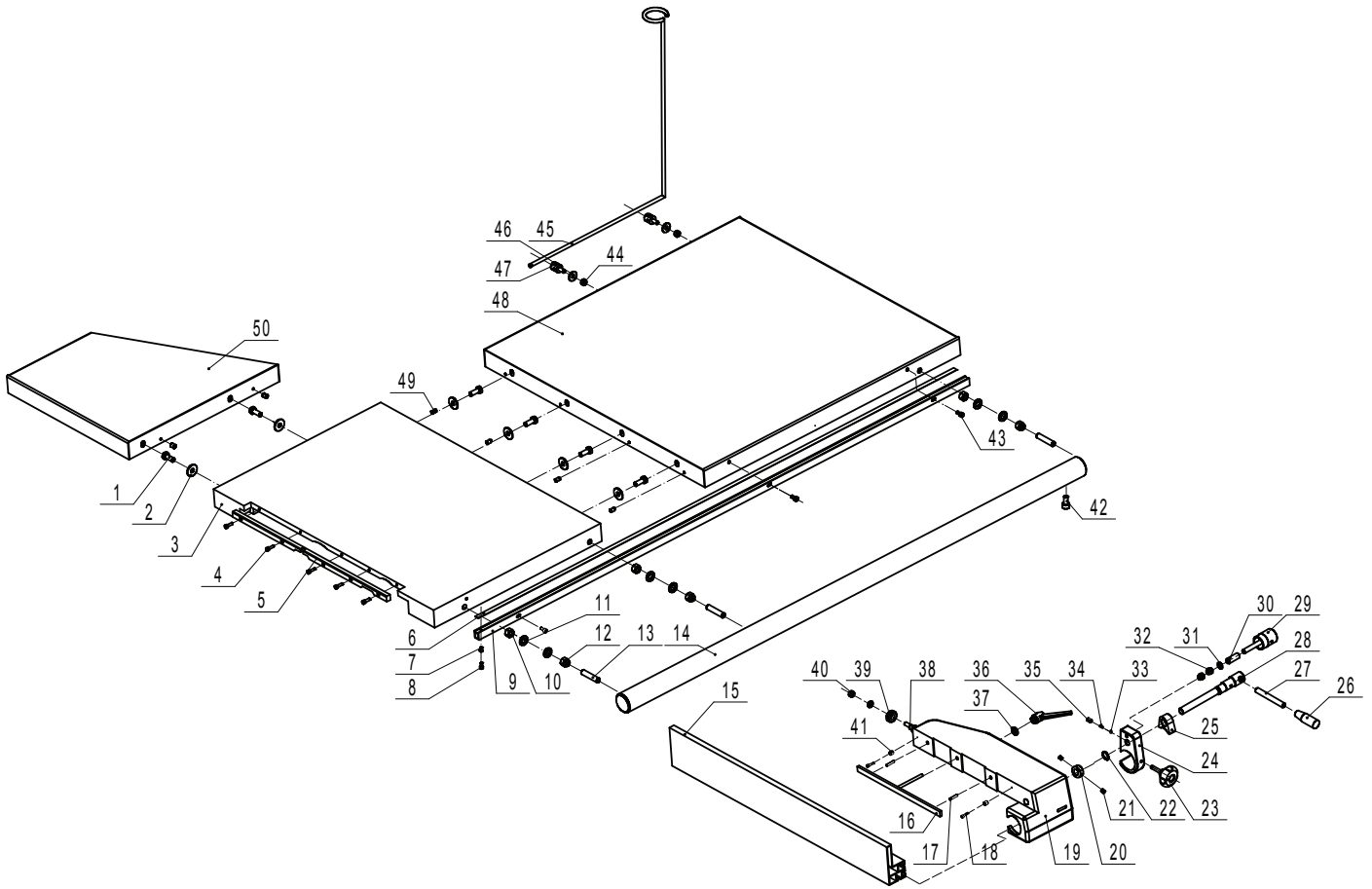

Item	Description	Part Number	Quantity	Item	Description	Part Number	Quantity
12-1	Hex bolt	46318	6	12-26	Handle glove	46343	1
12-2	Flat washer	46319	6	12-27	Locking lever	46344	1
12-3	Main table	46320	1	12-28	Handlebar	46345	1
12-4	Screw	46321	5	12-29	Adjusting handle	46346	1
12-5	Table insert	46322	1	12-30	Spacer bush	46347	1
12-6	Scale	46323	1	12-31	Flat washer	46348	2
12-7	Nut	46324	1	12-32	Nut	46349	2
12-8	Screw	46325	1	12-33	Screw	46350	1
12-9	Scale seat	46326	1	12-34	Steel ball	46351	1
12-10	Hex nut	46327	4	12-35	Pressure spring	46352	1
12-11	Flat washer	46328	8	12-36	Locking handle	46353	1
12-12	Self-locking nut	46329	4	12-37	Flat washer	46354	1
12-13	Set screw	46330	4	12-38	Adjusting spindle	46355	1
12-14	Guide rail	46331	1	12-39	Roller wheel	46356	1
12-15	"L" Rip fence	46332	1	12-40	Nut	46357	1
12-16	Locking plate	46333	1	12-41	Eccentric bushing	46358	2
12-17	Roll pin	46334	2	14-42	Screw	46359	1
12-18	Screw	46335	2	12-43	Screw	46360	1
12-19	Fence carrier	46336	1	12-44	Hex nut	46361	2
12-20	Retainer ring	46337	1	12-45	Bracket	46362	1
12-21	Set screw	46338	2	12-46	Washer	46363	2
12-22	Circlip ring	46339	1	12-47	Fixed block	46364	2
12-23	Round handle	46340	1	12-48	Right extension table	46365	1
12-24	Bracket	46341	1	12-49	Screw	46366	8
12-25	Bushing	46342	1	12-50	Rear extension table	46367	1

# 14. Parts Lists and Diagrams

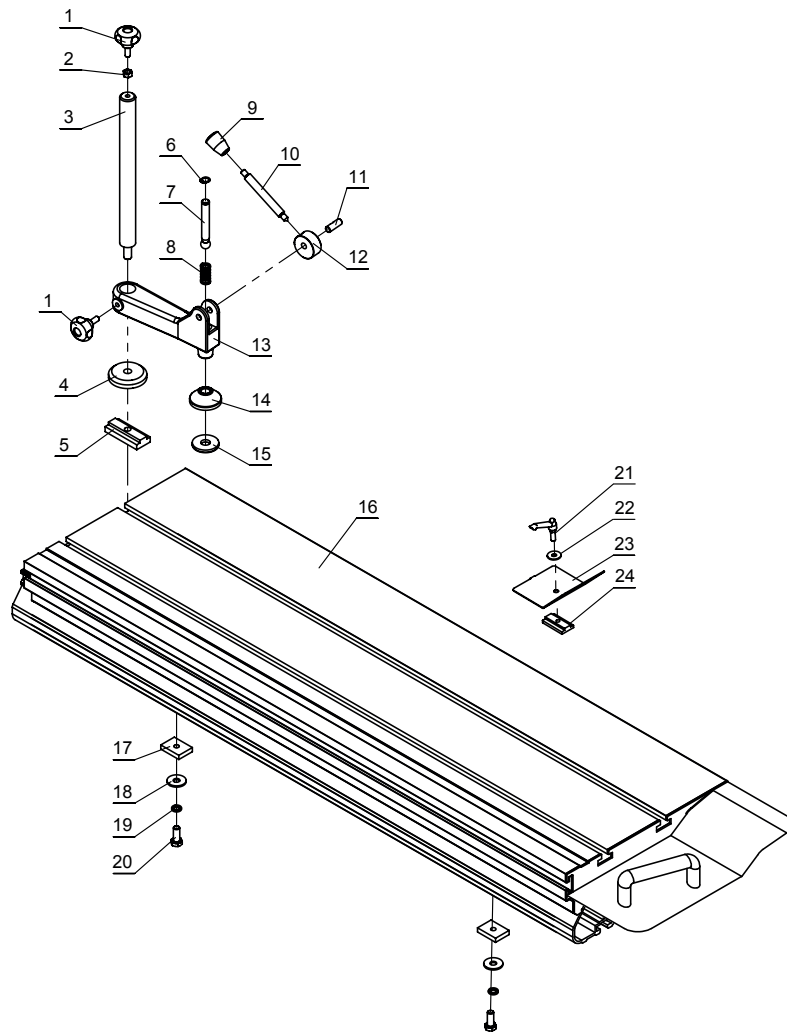

Item	Description	Part Number	Quantity
13-1	Round handle	46368	1
13-2	Hex nut	46369	1
13-3	Connecting rod	46370	1
13-4	Eccentric clamp	46371	1
13-5	Sliding block	46372	1
13-6	Circlip spring ring	46373	1
13-7	Ball rod	46374	1
13-8	Spring	46375	1
13-9	Handle sleeve	46376	1
13-10	Handle rod	46377	1
13-11	Shaft	46378	1
13-12	Cam wheel	46379	1
13-13	Connect arm	46380	1
13-14	Eccentric clamp	46381	1
13-15	Rubber gasket	46382	1
13-16	Sliding table	46383	1
13-17	Guide plate	46384	2
13-18	Big washer	46385	2
13-19	Spring washer	46386	2
13-20	Bolt	46387	2
13-21	Locking handle	46388	1
13-22	Big washer	46389	1
13-23	Press plate	46390	1
13-24	Sliding block	46391	1

# 14. Parts Lists and Diagrams

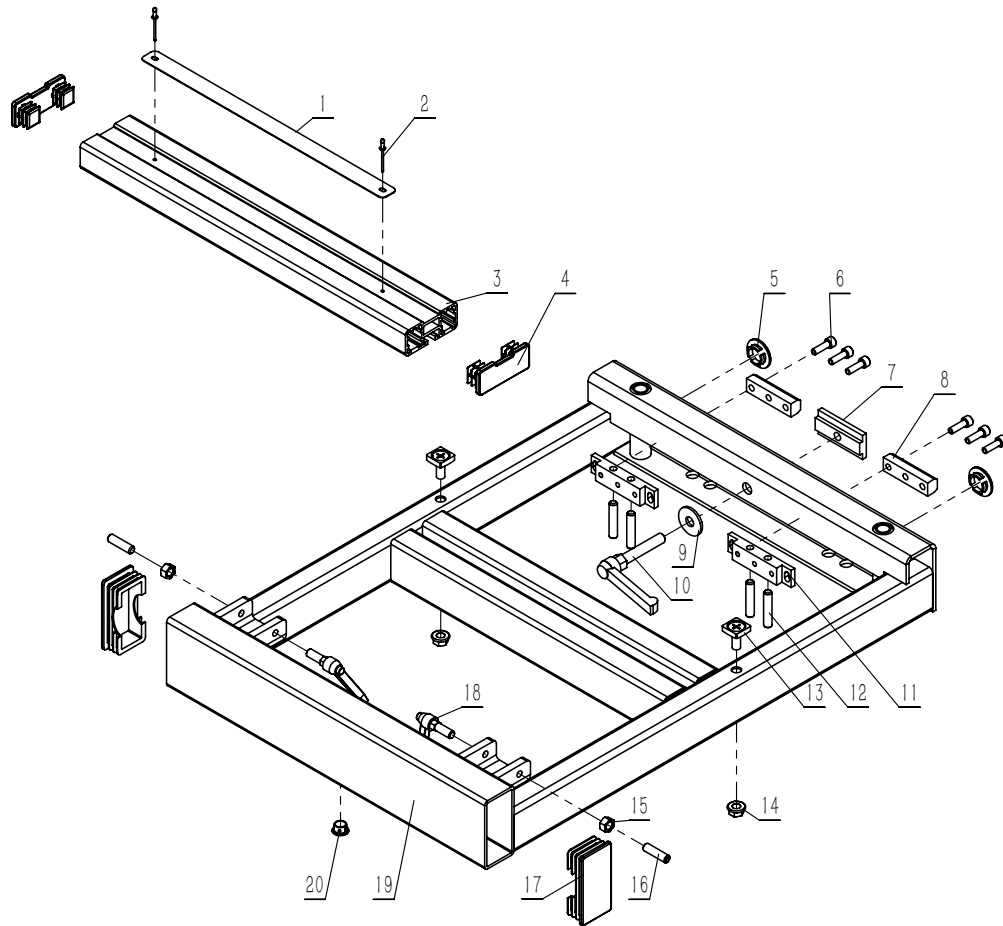

Item	Description	Part Number	Quantity
14-1	Angle scale	46392	1
14-2	Rivet	46393	2
14-3	Bracket	46394	1
14-4	End cap	46395	2
14-5	Wearing pad	46396	2
14-6	Screw	46397	6
14-7	Sliding block	46398	1
14-8	Guide block	46399	2
14-9	Big washer	46400	1
14-10	Locking handle	46401	1
14-11	Locking bolt	46402	2
14-12	Set screw	46403	4
14-13	Locking bolt	46404	2
14-14	Nut	46405	2
14-15	Hex nut	46406	2
14-16	Set screw	46407	2
14-17	End cap	46408	2
14-18	Locking handle	46409	2
14-19	Slide bracket	46410	1
14-20	Shaft sleeve	46411	1

# 14. Parts Lists and Diagrams

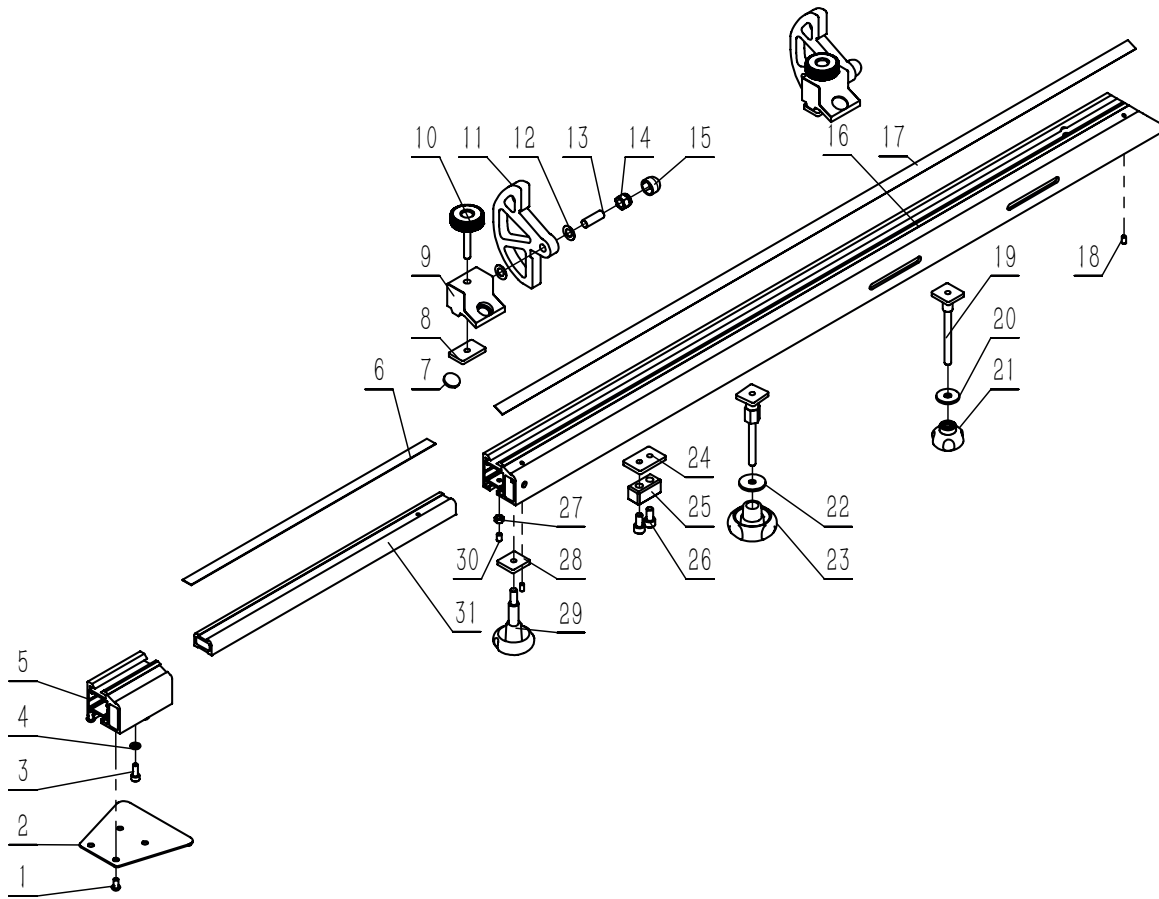

Item	Description	Part Number	Quantity	Item	Description	Part Number	Quantity
15-1	Screw	46412	4	15-17	Scale	46428	1
15-2	Plate	46413	1	15-18	Set screw	46429	2
15-3	Screw	46414	2	15-19	Sliding block	46430	2
15-4	Flat washer	46415	2	15-20	Washer	46431	1
15-5	Bracket	46416	1	15-21	Round handle	46432	1
15-6	Scale	46417	1	15-22	Washer	46433	1
15-7	Lens	46418	2	15-23	Round handle	46434	1
15-8	Locking plate	46419	2	15-24	Locking plate	46435	1
15-9	Plate	46420	2	15-25	Locking block	46436	1
15-10	Handle	46421	2	15-26	Screw	46437	2
15-11	Stop block	46422	2	15-27	Hex nut	46438	2
15-12	Spacer	46423	4	15-28	Locking plate	46439	1
15-13	Shaft	46424	2	15-29	Locking handle	46440	1
15-14	Nut	46425	2	15-30	Set screw	46441	2
15-15	Cap	46426	2	15-31	Bracket	46442	1
15-16	Bracket	46427	1				

# 14. Parts Lists and Diagrams

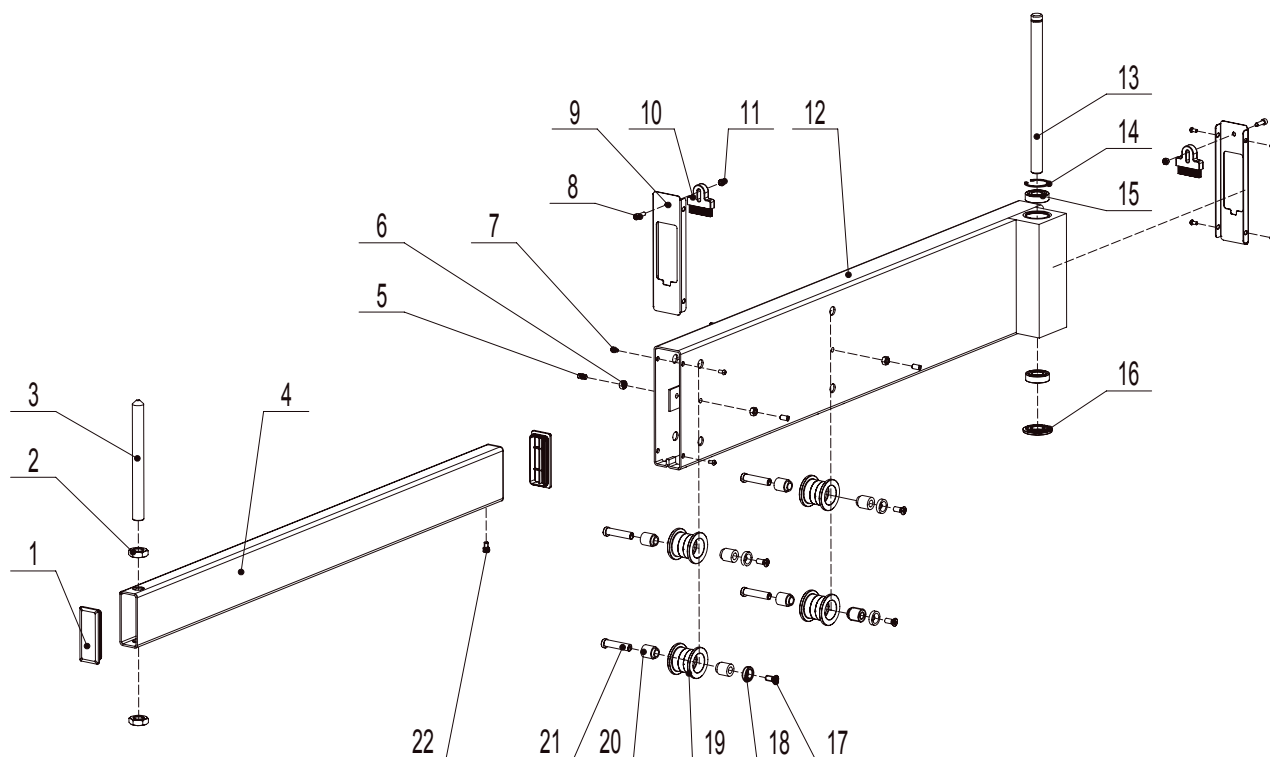

Item	Description	Part Number	Quantity
16-1	Plastic end cap	46443	2
16-2	Nut	46444	2
16-3	Support rod	46445	1
16-4	Telescopic rod	46446	1
16-5	Screw	46447	4
16-6	Hex nut	46448	4
16-7	Screw	46449	8
16-8	Screw	46450	2
16-9	Cover plate	46451	2
16-10	Brush	46452	2
16-11	Hex nut	46453	2
16-12	Support bracket	46454	1
16-13	Connect shaft	46455	1
16-14	Circlip spring ring	46456	1
16-15	Bearing	46457	2
16-16	Spacer	46458	1
16-17	Screw	46459	4
16-18	Washer	46460	4
16-19	Bearing roller	46461	3
16-20	Position sleeve	46462	8
16-21	Eccentric shaft	46463	4
16-22	Screw	46464	1

Item	Description	Part Number	Quantity
16-1	Plastic end cap	46443	2
16-2	Nut	46444	2
16-3	Support rod	46445	1
16-4	Telescopic rod	46446	1
16-5	Screw	46447	4
16-6	Hex nut	46448	4
16-7	Screw	46449	8
16-8	Screw	46450	2
16-9	Cover plate	46451	2
16-10	Brush	46452	2
16-11	Hex nut	46453	2
16-12	Support bracket	46454	1
16-13	Connect shaft	46455	1
16-14	Circlip spring ring	46456	1
16-15	Bearing	46457	2
16-16	Spacer	46458	1
16-17	Screw	46459	4
16-18	Washer	46460	4
16-19	Bearing roller	46461	3
16-20	Position sleeve	46462	8
16-21	Eccentric shaft	46463	4
16-22	Screw	46464	1



# 14. Parts Lists and Diagrams

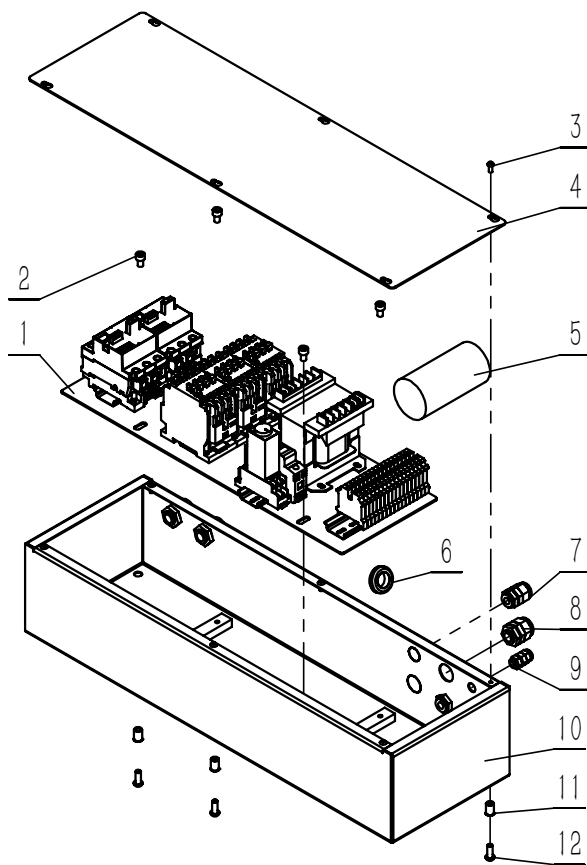

Item	Description	Part Number	Quantity
17-1	Electrical assembly	46465	1
17-2	Screw	46466	4
17-3	Screw	46467	6
17-4	Cover	46468	1
17-5	Capacitor (single-phase)	46469	1
17-6	Rubber bushing	46470	1
17-7	M16 cable gland	46471	2
17-8	M20 cable gland	46472	3
17-9	M10 cable gland	46473	1
17-10	Electrical box	46474	1
17-11	Nut	46475	3
17-12	Screw	46476	3

# EU Declaration of Conformity

**Cert No: EU / TS2 / 1**

**RECORD POWER LIMITED,**

Centenary House, 11 Midland Way, Barlborough Links,  
Chesterfield, Derbyshire S43 4XA

declares that the machinery described:-

1. Type: **Table Saw**
2. Model No: **TS2**
3. Serial No .....

Conforms with the following directives:-

MACHINERY DIRECTIVE	2006/42/EC
ELECTROMAGNETIC COMPATIBILITY DIRECTIVE	2004/108/EC

and conforms to the machinery example for which the  
EC Type-Examination Certificate No. **BM500093100001, BM503115530001**  
has been issued by **TUV Rheinland LGA Products GmbH**  
at: Tillystrasse 2, D90431 Nürnberg

and complies with the relevant essential health and safety requirements.

Signed..........Dated: **01/04/2020**  
**Andrew Greensted**  
Managing Director





# RECORD POWER

ESTABLISHED 1909®

## Woodworking Machinery and Accessories

Record Power Ltd, Centenary House, 11 Midland Way, Barlborough Links, Chesterfield, Derbyshire S43 4XA

Tel: +44 (0) 1246 571 020 Fax: +44 (0) 1246 571 030 [www.recordpower.co.uk](http://www.recordpower.co.uk)

To register a product and find your local stockist visit

**[recordpower.info](http://recordpower.info)**

Made in China